Radiation Measurement

LI-COR

Much confusion has existed regarding the measurement of radiation. This report presents a comprehensive summary of the terminology and units used in radiometry, photometry, and the measurement of photosynthetically active radiation (PAR). Measurement errors can arise from a number of sources, and these are explained in detail. Finally, the conversion of radiometric and photometric units to photon units is discussed. In this report, the International System of Units (SI) is used unless noted otherwise (9).

RADIOMETRY

Radiometry (1) is the measurement of the properties of radiant energy (SI unit: joule, J), which is one of the many interchangeable forms of energy. The rate of flow of radiant energy, in the form of an electromagnetic wave, is called the *radiant flux* (unit: watt, W; $1 \text{ W} = 1 \text{ J s}^{-1}$). Radiant flux can be measured as it flows from the *source* (the sun, in natural conditions), through one or more reflecting, absorbing, scattering and transmitting *media* (the Earth's atmosphere, a plant canopy) to the *receiving surface* of interest (a photosynthesizing leaf) (8).

Terminology and Units

Radiant flux is the amount of radiation coming from a source per unit time. Unit: watt, W.

Radiant intensity is the radiant flux leaving a point on the source, per unit solid angle of space surrounding the point. Unit: watts per steradian, W sr^{-1} .

Radiance is the radiant flux emitted by a unit area of a source or scattered by a unit area of a surface. Unit: $\text{W m}^{-2} \text{ sr}^{-1}$.

Irradiance is the radiant flux incident on a receiving surface from all directions, per unit area of surface. Unit: W m^{-2} .

Absorptance is the fraction of the incident flux that is absorbed by a medium.

Reflectance and *transmittance* are equivalent terms for the fractions that are reflected or transmitted.

Spectroradiometry: All the properties of the radiant flux depend on the *wavelength* of the radiation. The prefix *spectral* is added when the wavelength dependency is being described. Thus, the *spectral irradiance* is the irradiance at a given wavelength, per unit wavelength interval. The irradiance within a given waveband is the integral of the spectral irradiance with respect to wavelength (8). Unit: $\text{W m}^{-2} \text{ nm}^{-1}$. Spectral measurements can be made using the LI-1800 Portable Spectroradiometer.

Global solar radiation is the solar irradiance received on a horizontal surface (also referred to as the *direct* component of sunlight plus the *diffuse* component of skylight received together on a horizontal surface). This physical quantity is measured by a pyranometer such as the LI-200SA. Unit: W m^{-2} .

Direct solar radiation is the radiation emitted from the solid angle of the sun's disc, received on a surface perpendicular to the axis of this cone, comprising mainly unscattered and unreflected solar radiation. This physical quantity is measured by a pyrheliometer. Unit: W m^{-2} .

Diffuse solar radiation (sky radiation) is the downward scattered and reflected radiation coming from the whole hemisphere, with the exception of the solid angle subtended by the sun's disc. Diffuse radiation can be measured by a pyranometer mounted on a shadow band, or calculated using global solar radiation and direct solar radiation. Unit: W m^{-2} .

PHOTOSYNTHETICALLY ACTIVE RADIATION

In the past there has been disagreement concerning units and terminology used in radiation measurements in conjunction with the plant sciences. It is LI-COR's policy to adopt the recommendations of the international committees, such as the Commission Internationale de l'Éclairage (CIE), the International Bureau of Weights and Measures, and the International Committee on Radiation Units. The International System of Units (SI) should be used wherever a suitable unit exists (9).

Units

The SI unit of radiant energy flux is the watt (W). There is no official SI unit of photon flux. The *mole of photons* and *einstein* are commonly used to designate Avogadro's number of photons ($6.022 \cdot 10^{23}$ photons). The einstein has been used in the past in plant science, however, most societies now recommend the use of the mole since the mole is an SI unit. When either of these definitions are used, the quantity of photons in a mole is equal to the quantity of photons in an einstein ($1 \text{ mole} = 1 \text{ einstein} = 6.022 \cdot 10^{23}$ photons). Note: The einstein has also been used in books on photochemistry, photobiology and radiation physics as the *quantity of radiant energy in Avogadro's number of photons* (5). This definition is not used in photosynthesis studies.

Terminology

LI-COR continues to follow the lead of the Crop Science Society of America, Committee on Terminology (10) and other societies (11) until international committees put forth further recommendations. LI-COR has introduced the term *Photosynthetic Photon Flux Fluence Rate* (PPFFR). Oceanographers and limnologists have sometimes called this *Quantum Scaler Irradiance* or *Photon Spherical Irradiance*.

Photosynthetically Active Radiation (PAR) is defined as radiation in the 400 to 700 nm waveband. PAR is the general radiation term which covers both photon terms (7) and energy terms.

Photosynthetic Photon Flux Density (PPFD) is defined as the photon flux density of PAR, also referred to as *Quantum Flux Density*. This is the number of photons in the 400-700 nm waveband incident per unit time on a unit surface. The ideal PPFD sensor responds equally to all photons in the 400-700 nm waveband and has a cosine response. This physical quantity is measured by a cosine (180°) quantum sensor such as the LI-190SA or LI-192SA. The LI-191SA Line Quantum Sensor also measures PPFD. Figure 1 shows an ideal quantum response curve and the typical spectral response curve of LI-COR quantum sensors.

Units: $1 \mu\text{mol s}^{-1} \text{ m}^{-2} \equiv 1 \mu\text{E s}^{-1} \text{ m}^{-2} \equiv 6.022 \cdot 10^{17} \text{ photons s}^{-1} \text{ m}^{-2}$.

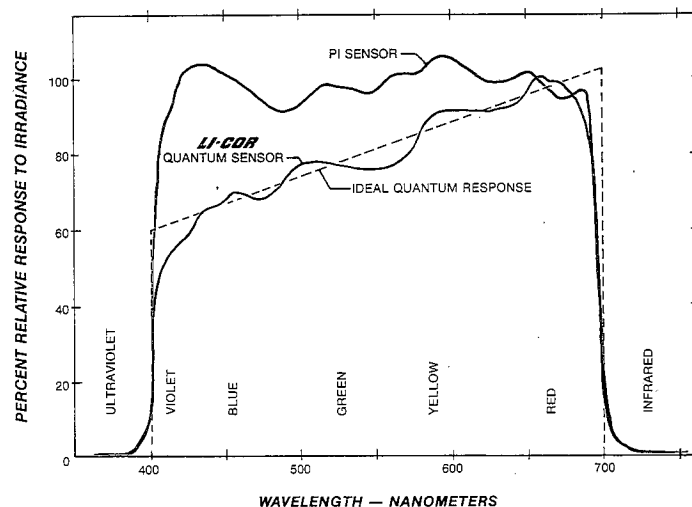

Figure 1. Typical spectral response of LI-COR Quantum Sensors and a photosynthetic irradiance sensor vs. wavelength and ideal quantum response.

Photosynthetic Photon Flux Fluence Rate (PPFFR) is defined as the photon flux fluence rate of PAR, also referred to as *Quantum Scaler Irradiance* or *Photon Spherical Irradiance*. This is the integral of photon flux radiance at a point over all directions about the point. The ideal PPFFR sensor has a spherical collecting surface which exhibits the properties of a cosine receiver at every point on its surface (Figure 2) and responds equally to all photons in the 400-700 nm waveband (Figure 1). This physical quantity is measured by a spherical (4π collector) quantum sensor such as the LI-193SA.

Units: $1 \mu\text{mol s}^{-1} \text{ m}^{-2} \equiv 1 \mu\text{E s}^{-1} \text{ m}^{-2} \equiv 6.022 \cdot 10^{17} \text{ photons s}^{-1} \text{ m}^{-2} \equiv 6.022 \cdot 10^{17} \text{ quanta s}^{-1} \text{ m}^{-2}$.

Note: There is no unique relationship between the PPFD and the PPFFR. For a collimated beam at normal incidence, they are equal; while for perfectly diffuse radiation, the PPFFR is 4 times the PPFD. In practical situations the ratio will be somewhere between 1 and 4.

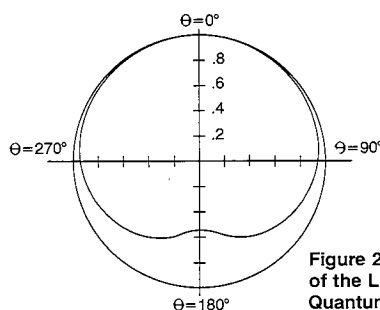

Figure 2. Typical Angular Response of the LI-193SB Spherical Quantum Sensor.

Photosynthetic Irradiance (PI) is defined as the radiant energy flux density of PAR. This is the radiant energy incident per unit time on a unit surface. The ideal PI Sensor responds equally to energy in the 400-700 nm waveband (Figure 1) and has a cosine response. Unit: $W m^{-2}$. Note: There is no unique relationship between PI and PPFD. This depends on the spectral properties of the light source (8).

PHOTOMETRY

Photometry refers to the measurement of *visible radiation* (light) with a sensor having a spectral responsivity curve equal to the average human eye. Photometry is used to describe lighting conditions where the eye is the primary sensor, such as illumination of work areas, interior lighting, television screens, etc. Although photometric measurements have been used in the past in plant science, PPFD and irradiance are the preferred measurements. The use of the word "light" is inappropriate in plant research. The terms "ultraviolet light" and "infrared light" clearly are contradictory (8).

The spectral responsivity curve of the standard human eye at typical light levels is called the *CIE Standard Observer Curve* (photopic curve), and covers the waveband of 380-770 nm. The human eye responds differently to light of different colors and has maximum sensitivity to yellow and green (Figure 3). In order to make accurate photometric measurements of various colors of light or from differing types of light sources, a photometric sensor's spectral responsivity curve must match the CIE photopic curve very closely.

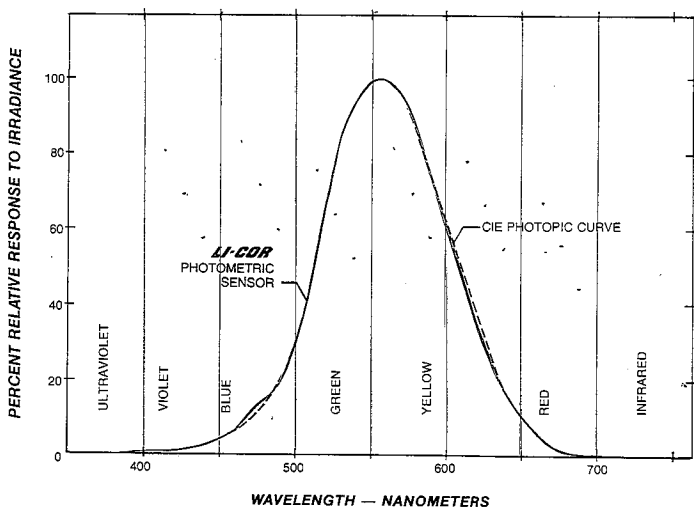

Figure 3. Typical spectral response of LI-COR Photometric Sensors vs. the CIE photopic response curve.

Terminology and Units (4)

Luminous flux is the amount of radiation coming from a source per unit time, evaluated in terms of a standardized visual response. Unit: lumen, lm.

Luminous intensity is the luminous flux per unit solid angle in the direction in question. Unit: candela, cd. One candela is one $lm sr^{-1}$.

Luminance is the quotient of the luminous flux at an element of the surface surrounding the point and propagated in directions defined by an elementary cone containing the given direction, by the product of the solid angle of the cone and the area of the orthogonal projection of the element of the surface on a plane perpendicular to the given direction. Unit: $cd m^{-2}$; also, $lm sr^{-1} m^{-2}$. This unit is also called the nit.

Illuminance is defined as the density of the luminous flux incident at a point on a surface. Average illuminance is the quotient of the luminous flux incident on a surface by the area of the surface. This physical quantity is measured by a cosine photometric sensor such as the LI-210SA. Unit: lux, lx. One lux is one $lm m^{-2}$.

MEASUREMENT ERRORS

At a Controlled Environments Working Conference in Madison, Wisconsin, USA (1979), an official from the U.S. National Bureau of Standards (NBS) stated that one could not expect less than 10 to 25% error in radiation measurements made under non-ideal conditions. In order to clarify this area, the sources of errors which the researcher must be aware

of when making radiation measurements have been tabulated. Refer also to the specifications given with each sensor for further details.

Absolute Calibration Error

Absolute calibration error depends on the source of the lamp standard and its estimated uncertainty at the time of calibration, accuracy of filament to sensor distance, alignment accuracy, stray light, and the lamp current measurement accuracy. Where it is necessary to use a transfer sensor (such as for solar calibrations) additional error will be introduced. LI-COR quantum and photometric sensors are calibrated against a working quartz halogen lamp. These working quartz halogen lamps have been calibrated against laboratory standards traceable to the NBS. Standard lamp current is metered to 0.035% accuracy. Microscope and laser alignment in the calibration setup reduce alignment errors to less than 0.1%. Stray light is reduced by black velvet to less than 0.1%. The absolute calibration accuracy is limited to the uncertainty of the NBS traceable standard lamp. The absolute calibration specification for LI-COR sensors is $\pm 5\%$ traceable to the NBS. This accuracy is conservatively stated and the error is typically $\pm 3\%$. Absolute calibrations and spectral responses of LI-COR sensors have been checked by the National Research Council of Canada (NRC) to insure the accuracy and quality of LI-COR calibrations.

Relative Error (Spectral Response Error)

This error is also called activity error or spectral correction error. This error is due to the spectral response of the sensor not conforming to the ideal spectral response. This error occurs when measuring radiation from any source which is spectrally different than the calibration source.

The quantum and photometric sensor spectral response conformity is checked by LI-COR using a monochromator with a 2.5 nm bandwidth and a blackened thermopile-calibrated silicon photodiode. The spectral response of the sensor is achieved by the use of computer-tailored filter glass. Relative errors for various sources due to a non-ideal spectral response are checked both by actual measurement and by a computer program which utilizes the source spectral irradiance data and the sensor spectral response data.

All LI-COR quantum and photometric sensors have relative errors $< 7\%$ when used in growth chambers, daylight, greenhouses, plant canopies and aquatic conditions. When used with sources that have strong spectral lines such as gas lamps or lasers, this error could be larger depending on the location of the lines.

The LI-COR pyranometer measures irradiance from the sun plus sky. The LI-200SA is not spectrally ideal (equal spectral response from 280-2800 nm). See Figure 4. Therefore, it should be used only under natural, unobstructed daylight conditions. NOAA states in a test report that for clear, unobstructed daylight conditions, the LI-COR pyranometer compares very well with class one thermopile pyranometers (3). The LI-200SA is a WMO (World Meteorological Organization) class two pyranometer. *The LI-200SA should not be used under spectrally different radiation (than the sun), such as in growth chambers, greenhouses, and plant canopies. Under such artificial or shaded conditions, a thermopile pyranometer should be used.*

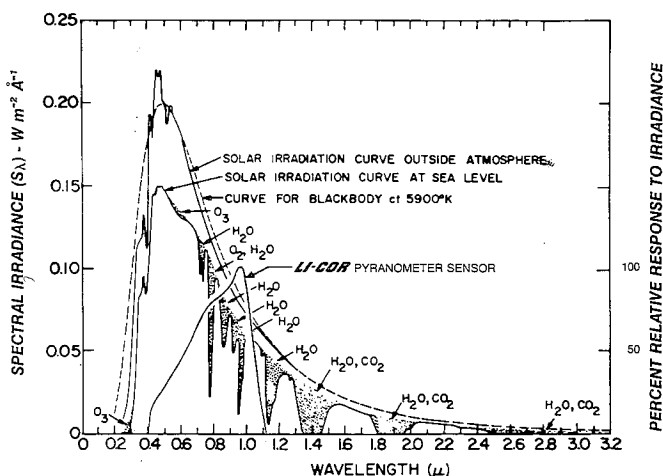

Figure 4. The LI-200SA Pyranometer spectral response is illustrated along with the energy distribution in the solar spectrum (5).

Spatial Error

This error is caused by a sensor not responding to radiation at various incident angles. Spatial error consists of the cosine error (or the angular error) and azimuth error.

COSINE ERROR

A sensor with a cosine response (follows Lambert's cosine law) allows measurement of flux densities through a given plane, i.e. flux densities per unit area. When a parallel beam of radiation of given cross-sectional area spreads over a flat surface, the area that it covers is inversely proportional to the cosine of the angle between the beam and a plane normal to the surface. Therefore, the irradiance due to the beam is proportional to the cosine of the angle. A radiometer, whose response to beams coming from different directions follows the same relationship, is said to be "cosine-corrected" (6). A sensor without an accurate cosine correction can give a severe error under diffuse radiation conditions within a plant canopy, at low solar elevation angles, under fluorescent lighting, etc.

Cosine response is measured by placing the sensor on a platform which can be adjusted to rotate the sensor about an axis placed across the center of the measuring surface. A collimated source is directed at normal incidence and the output of the sensor is measured as the angle of incidence is varied. The cosine error at angle θ is the percent difference of the ratio of the measured output at angle θ and normal incidence (angle 0°) as compared to the cosine of angle θ . This is repeated for various azimuth angles as necessary.

The LI-190SA, LI-200SA and LI-210SA are fully corrected cosine sensors. These sensors have a typical cosine error of less than 5% up to an 80° angle of incidence. Totally diffuse radiation introduces a cosine error of approximately 2.5%. For sun plus sky at a sun elevation of 30° (60° angle of incidence), the error is $\approx 2\%$.

The LI-192SA sensor has a slightly greater cosine error since this sensor has a cosine response optimized for both air and water.

The LI-191SA uses uncorrected acrylic diffusers and has a greater error at high angles of incidence. For totally diffuse radiation, the error is $\approx 8\%$. For conditions within canopies, the error is less because the radiation is not totally diffuse.

ANGULAR ERROR

A spherical PPFRR sensor measures the total flux incidence on its spherical surface divided by the cross-sectional area of the sphere. Angular error is measured by directing a collimated source at normal incidence and rotating the sensor 360° about an axis directly through the center of the sphere at 90° from normal incidence. This is repeated for various azimuth angles as necessary to characterize the sensor.

The LI-193SA angular error is due to variations in density in the diffusion sphere and the sphere area lost because of the sensor base (Figure 2). This error is less than -10% for totally diffuse radiation, but is usually much less than -10% because the upwelling radiation is much smaller than the downwelling radiation.

AZIMUTH ERROR

This is a subcategory of both cosine and angular error. It is specified separately at a particular angle of incidence. This error is the percent change of the sensor output as the sensor is rotated about the normal axis at a particular angle of incident radiation. This error is less than $\pm 1\%$ at 45° for the LI-190SA, LI-192SA, LI-200SA, and LI-210SA sensors. The error is less than $\pm 3\%$ for the LI-191SA and LI-193SA sensors.

Displacement Error

In highly turbid waters, the LI-193SA Spherical Sensor will indicate high PPFRR values due to the displacement of water by the sensor sphere volume. This is because the point of measurement is taken to be at the center of the sphere, but the attenuation which would have been provided by the water within the sphere is absent. This error is typically +6% for water with an attenuation coefficient of 3 m^{-1} (2).

Tilt Error

Tilt error exists when a sensor is sensitive to orientation due to the effects of gravity. This exists primarily in thermopile type detectors. Silicon type detectors do not have this error. All LI-COR sensors are of the latter type and have no tilt error. This error in the LI-200SA Pyranometer is nonexistent and has an advantage over thermopile type detectors for solar radiation measurements (3).

Linearity Error

Linearity error exists when a sensor is not able to follow proportionate changes in radiation. The type of silicon detectors used in LI-COR sensors have a linearity error of less than $\pm 1\%$ over seven decades of dynamic range.

Fatigue Error

Fatigue error exists when a sensor exhibits hysteresis. This is common in selenium-based illumination meters and can add a considerable error. For this reason, LI-COR sensors incorporate only silicon detectors which exhibit no fatigue error.

Temperature Coefficient Error

Temperature coefficient error exists when the output of a sensor changes with a constant input. This error is typically less than $\pm 0.1\%$ per $^\circ\text{C}$ for the LI-190SA, LI-191SA, LI-192SA, LI-193SA, and LI-210SB sensors. This error is slightly higher for the LI-200SA.

Response Time Error

This error exists when the source being measured changes rapidly during the period of measurement.

Averaging: Large errors can exist when measuring radiation under rapidly changing conditions such as changing cloud cover and wind if measuring within a crop canopy, and waves if measuring underwater. The use of an integrating meter to average the reading will eliminate this error.

Instantaneous: When radiation measurements are desired over a period of time (much less than the response time of the system), large errors can exist. For example, if one were to measure the radiation from a pulsed source (such as a gas discharge flash lamp) with a typical system designed for environmental measurements, the reading would be meaningless. Such a measurement should not be made with LI-COR instruments without consultation with LI-COR.

Long-Term Stability Error

This error exists when the calibration of a sensor changes with time. This error is usually low for sensors using high quality silicon photovoltaic/photodiodes and glass filters. LI-COR uses only these high quality components. The use of Wratten filters and/or inexpensive silicon or selenium cells add significantly to long-term stability error. The stability error of LI-COR sensors is typically $\pm 2\%$ per year. **Important: Customers should have their sensors recalibrated every two years.**

Immersion Effect Error

A sensor with a diffuser for cosine correction will have an immersion effect when immersed in water. Radiation entering the diffuser scatters in all directions within the diffuser, with more radiation lost through the water-diffuser interface than in the case when the sensor is in the air. This is because the air-diffuser interface offers a greater ratio of indices of refraction than the water-diffuser interface. LI-COR provides a typical immersion effect correction factor for the underwater sensors. Immersion effect error is the difference between this typical figure and the actual figure for a given sensor in a particular environment. Since LI-COR test measurements are done in clear water, the error is also dependent on other variables such as turbidity, salinity, etc. Immersion effect error is typically $\pm 2\%$ or less. A complete report on the immersion effect properties of LI-COR underwater sensors is available from LI-COR.

Surface Variation Error

In general, the absolute responsivity and the relative spectral responsivity are not constant over the radiation-sensitive surface of sensors. This error has little effect in environmental measurements except for spatial averaging sensors such as the LI-191SA. This error is $< \pm 7\%$ for the LI-191SA.

User Errors

SPATIAL USER ERROR

This is different than sensor-caused spatial error. Spatial user error can be introduced by using a single small sensor to characterize the radiation profile within a crop canopy or growth chamber. The flux density measured on a given plane can vary considerably due to shadows and sunflecks. To neglect this in measurements can introduce errors up to 1000%. Multiple sensors or sensors on track scanners can be used to minimize this error. If track scanners are used, the output of the sensors must be integrated.

The LI-191SA Line Quantum Sensor, which spatially averages radiation over its one meter length, minimizes this error and allows one person to easily make many measurements in a short period of time. Another method, although not as accurate, is to use an integrating meter and the LI-190SA Quantum Sensor and physically scan the sensor by hand within the canopy while integrating the output with the meter.

Another type of spatial user error can be caused by misapplication of a cosine-corrected sensor where a spherical sensor would give a more accurate measurement. An example is in underwater photosynthetic radiation measurements when studying phytoplankton.

USER SETUP/APPLICATION ERRORS

These errors include such causes as:

- Reflections or obstructions from clothing, buildings, boats, etc.
- Dust, flyspecks, seaweeds, bird droppings, etc.
- Shock, causing permanent damage of optics within the sensor.
- Submersion of terrestrial sensors in water for an extended period (partial or total). Rain doesn't affect the sensors since they are completely weatherproof.
- Use of the incorrect calibration constant.
- Incorrect interpolation of analog meters.
- Using the wrong meter function.
- Failure to have sensors recalibrated periodically.

Readout Error

This error is due to the readout instrument as distinguished from the sensor. Zero drift, temperature, battery voltage, electronic stability, line voltage, humidity and shock are all factors which can contribute to readout error. The use of electronic circuitry such as chopper-stabilized amplifiers and voltage regulators in LI-COR meters largely eliminates many of these problems: zero drift, temperature, battery voltage, electronic stability, line voltage.

Total Error

The errors given are largely independent of each other and are random in polarity and magnitude. Therefore, they can be summed in quadrature (the square root of the sum of the squares). The total error is shown below for an LI-190SA Quantum Sensor and LI-COR meters when used for measuring lighting in a typical growth chamber or natural daylight over a temperature range of 15° to 35°C.

	Typical Error
Absolute Error	5% max., 3% typical
Relative (spectral response) Error	5%
Spatial (cosine) Error	2%
Displacement Error	0%
Tilt Error	0%
Linearity Error	0%
Fatigue Error	0%
Sensor Temperature Coefficient Error	1% (0.1% per °C)
Response Time Error	0%
Long-term Stability Error	2% (2% per year)
Immersion Effect Error	0%
Surface Variation Error	0%
Readout Error	1%
User Error	?

The total error = Square Root (5x5 + 5x5 + 2x2 + 1x1) = 7.6%. All of the above errors are minimized by LI-COR through design and calibration. While this error seems reasonably low, it must be remembered that no user error has been added, and that statistically it is possible that all the errors could be of the same polarity. The sum of the errors (less the user error) could equal 16% in the worst case. The absolute error is conservatively stated and is more typically ±3%. User error in vegetation canopies where shadows and sunflecks exist can be very large (1000%) and one of the methods described under *Spatial User Error* should be employed.

When purchasing a radiation measuring system, it is necessary to insure that the spatial (cosine, etc.) and relative spectral response errors are as low as possible. These two errors depend upon the skill and expertise of the designer and manufacturer. Some manufacturers deliberately do not give specifications for these errors and the user can expect large errors. The absolute error is largely dependent on the NBS lamp standard. Minimization of this error can be achieved by the more experienced companies through the use of precise techniques and expensive capital equipment. In order to insure long-term stability, it is necessary that the manufacturer use the highest quality silicon photovoltaic/photodiodes and only the best glass filters. Modern electronic readout instruments virtually eliminate readout error.

The user should be aware of all the types of errors that can occur, particularly the relative and spatial errors, since these can add considerably to the total error. LI-COR has and continues to put forth a considerable effort to insure that the spectral and cosine response of all quantum and photometric sensors are as nearly ideal as optically possible. This assures LI-COR customers of the best possible accuracy.

CONVERSION OF UNITS

Conversion of Photon Units to Radiometric Units

Conversion of quantum sensor output in $\mu\text{mol s}^{-1} \text{m}^{-2}$ (400-700 nm) to radiometric units in W m^{-2} (400-700 nm) is complicated. The conversion factor will be different for each light source, and the spectral distribution curve of the radiant output of the source (W_λ ; $\text{W m}^{-2} \text{nm}^{-1}$) must be known in order to make the conversion. The accurate measurement of W_λ is a difficult task, which should not be attempted without adequate equipment and calibration facilities. The radiometric quantity desired is the integral of W_λ over the 400-700 nm range, or:

$$W_T = \int_{400}^{700} W_\lambda d\lambda \quad (1)$$

At a given wavelength λ , the number of photons per second is

$$\text{photons s}^{-1} = \frac{W_\lambda}{hc/\lambda} \quad (2)$$

where $h = 6.63 \cdot 10^{-34}$ joule-s (Planck's constant), $c = 3.00 \cdot 10^8$ m s⁻¹ (velocity of light) and λ is in nm. hc/λ is the energy of one photon. Then, the total number of photons per second in the 400-700 nm range is

$$\int_{400}^{700} \frac{W_\lambda}{hc/\lambda} d\lambda \quad (3)$$

This is the integral which is measured by the sensor. If R is the reading of the quantum sensor in $\mu\text{mol s}^{-1} \text{m}^{-2}$ ($1 \mu\text{mol s}^{-1} \text{m}^{-2} \equiv 6.022 \cdot 10^{17}$ photons s⁻¹ m²), then

$$6.022 \cdot 10^{17} (R) = \int_{400}^{700} \frac{W_\lambda}{hc/\lambda} d\lambda \quad (4)$$

Combining Eq. (1) and Eq. (4) gives

$$W_T = 6.022 \cdot 10^{17} (Rhc) \frac{\int_{400}^{700} W_\lambda d\lambda}{\int_{400}^{700} \lambda W_\lambda d\lambda} \quad (5)$$

To achieve the two integrals, discrete summations are necessary. Also, since W_λ appears in both the numerator and the denominator, the normalized curve N_λ may be substituted for it. Then

$$W_T = 6.022 \cdot 10^{17} (Rhc) \frac{\sum_i N_{\lambda_i} \Delta\lambda}{\sum_i \lambda_i N_{\lambda_i} \Delta\lambda} \quad (6)$$

where $\Delta\lambda$ is any desired wavelength interval, λ_i is the center wavelength of the interval and N_{λ_i} is the normalized radiant output of the source at the center wavelength. In final form this becomes

$$W_T \approx 119.8 (R) \frac{\sum_i N_{\lambda_i}}{\sum_i \lambda_i N_{\lambda_i}} \text{ W m}^{-2} \quad (7)$$

where R is the reading in $\mu\text{mol s}^{-1} \text{m}^{-2}$.

The following procedure should be used in conjunction with Eq. (7).

1. Divide the 400-700 nm range in n intervals of equal wavelength spacing $\Delta\lambda$.
2. Determine the center wavelength (λ_i) of each interval.
3. Determine the normalized radiant output of the source (N_{λ_i}) at each of the center wavelengths.
4. Sum the normalized radiant outputs as determined in Step 3 to find $\sum_i N_{\lambda_i}$.

5. Multiply the center wavelength by the normalized radiant output at that wavelength for each interval.

6. Sum the products determined in Step 5 to find $\sum_i y_{\lambda_i} N_{\lambda_i}$.

7. Use Eq. (7) to find W_T in $W m^{-2}$, where R is the quantum sensor output in $\mu mol s^{-1} m^{-2}$.

The following approximation assumes a flat spectral distribution curve of the source over the 400-700 nm range (equal spectral irradiance over the 400-700 nm range) and is shown as an example.

Given: $i = 1$
 $\Delta\lambda = 300 \text{ nm}$
 $\lambda_i = 550 \text{ nm}$

$$W_T \approx 119.8 (R) \left(\frac{N(550)}{550 \cdot N(550)} \right) = \frac{119.8(R)}{550} = 0.22(R) W m^{-2}$$

or

$$1 W m^{-2} \approx 4.6 \mu mol s^{-1} m^{-2}$$

This conversion factor is within $\pm 8.5\%$ of the factors determined by McCree as listed in Table I (8).

Conversion of Photon Units to Photometric Units

To convert photon units $\mu mol s^{-1} m^{-2}$, 400-700 nm) to photometric units (lux 400-700 nm), use the above procedure, except

a) Replace Eq. (1) with

$$Lux = 683 \int_{400}^{700} y_{\lambda} W_{\lambda} d\lambda$$

where y_{λ} is the luminosity coefficient of the standard CIE curve with $y_{\lambda} = 1$ at 550 nm and W_{λ} is the spectral irradiance ($W m^{-2} nm^{-1}$).

b) Replace Eq. (5) with

$$Lux = (683) (6.022 \cdot 10^{17}) (Rhc) \frac{\int_{400}^{700} y_{\lambda} W_{\lambda} d\lambda}{\int_{400}^{700} \lambda W_{\lambda} d\lambda}$$

c) Replace Eq. (6) with

$$Lux = (683) (6.022 \cdot 10^{17}) (Rhc) \frac{\sum_i y_{\lambda_i} N_{\lambda_i} \Delta\lambda}{\sum_i \lambda_i N_{\lambda_i} \Delta\lambda}$$

d) Replace Eq. (7) with

$$Lux = 8.17 \cdot 10^4 (R) \frac{\sum_i y_{\lambda_i} N_{\lambda_i}}{\sum_i \lambda_i N_{\lambda_i}}$$

e) Replace Step 4 with:

4a) Multiply the luminosity coefficient (y_{λ}) of the center wavelength by the normalized radiant output (N_{λ}) at that wavelength for each interval.

4b) Sum the products determined in Step 4a to find $\sum_i y_{\lambda_i} N_{\lambda_i}$.

The following approximation assumes a flat spectral distribution curve of the source over the 400-700 nm range (equal spectral irradiance over the 400-700 nm range) and is shown as an example.

Given: $i = 1$ to 31
 $\Delta\lambda = 10 \text{ nm}$
 $\lambda_1 = 400, \lambda_2 = 410, \lambda_3 = 420, \dots, \lambda_{31} = 700$
 $N_{\lambda} = 1$ for all wavelengths
 $y_{\lambda_1} = 0.0004, y_{\lambda_2} = 0.0012, y_{\lambda_3} = 0.004, \dots, y_{\lambda_{31}} = 0.0041$

$$Lux = 8.17 \cdot 10^4 (R) \frac{\sum_i y_{\lambda_i}}{\sum_i \lambda_i} = 8.17 \cdot 10^4 (R) \left(\frac{10.682}{17050} \right)$$

$$Lux = 51.2 R, \text{ where } R \text{ is in } \mu mol s^{-1} m^{-2}$$

Or,

$$1000 \text{ lux} = 1 \text{ klux} = 19.5 \mu mol s^{-1} m^{-2}$$

Table I. Approximate conversion factors for various light sources.
(8) (PAR waveband 400-700 nm)

To convert	Light source					
	Daylight	Metal halide	Sodium (HP)	Mercury	White fluor.	Incand.
$W m^{-2}$ (PAR) to $\mu mol s^{-1} m^{-2}$ (PAR)	4.6	4.6	5.0	4.7	4.6	5.0
klux to $\mu mol s^{-1} m^{-2}$ (PAR)	18	14	14	14	12	20
klux to $W m^{-2}$ (PAR)	4.0	3.1	2.8	3.0	2.7	4.0

Your comments on the subjects addressed in this report or any other measurement problems are always welcome and will be treated as valuable inputs.

William W. Biggs, Author

1. CIE (Commission Internationale de l'Eclairage). 1970. International lighting vocabulary, 3rd edn. Bureau Central de la CIE. Paris.
2. Combs, W. S., Jr., 1977. The measurement and prediction of irradiances available for photosynthesis by phytoplankton in lakes. Ph.D. thesis, Univ. of Minnesota, Limnology.
3. Flowers, E. C. 1978. Comparison of solar radiation sensors from various manufacturers. In: 1978 annual report from NOAA to the DOE.
4. Illuminating Engineering Society of North America. 1981. Nomenclature and definitions for illuminating engineering. Publication RP-16, ANSI/IES RP-16-1980. New York.
5. Incoll, L.D., S.P. Long and M.A. Ashmore. 1981. SI units in publications in plant science. In: Commentaries in Plant Sci. Vol. 2, pp. 83-96, Pergamon, Oxford.
6. Kondratyev, K. Ya. 1969. Direct solar radiation. In: Radiation in the atmosphere. Academic Press, New York, London.
7. McCree, K. J. 1972. Test of current definitions of photosynthetically active radiation against leaf photosynthesis data. Agric. Meteorol. 10:443-453.
8. _____. 1981. Photosynthetically active radiation. In: Physiological plant ecology. Lange, O. L., P. Nobel, B. Osmond and H. Ziegler (ed). Vol. 12A, Encyclopedia of plant physiology (new series). Springer-Verlag. Berlin, Heidelberg, New York.
9. Page, C. H. and P. Vigoureaux (ed). 1977. The international system of units (SI). Nat. Bur. of Stand. Special Publ. 330, 3rd edn. U.S. Govt. Printing Office, Washington D.C., U.S.A.
10. Shibbes, R. 1976. Committee Report. Terminology pertaining to photosynthesis. Crop Sci. 16:437-439.
11. Thimijan, R. W., and R. D. Heins. 1983. Photometric, radiometric, and quantum light units of measure: A review of procedures for interconversion. HortScience. 18:818-822.

LI-COR Calibrations

All LI-COR sensors (except pyranometers) are calibrated using working standard quartz halogen lamps which have been calibrated against reference standard lamps traceable to the U.S. National Bureau of Standards (NBS). Standard lamp current is metered to 0.035% accuracy. Microscope and laser alignment in the calibration setup reduce alignment errors to less than 0.1%. Stray light is reduced to less than 0.1% by a black velvet background. The absolute calibration specification for LI-COR sensors is $\pm 5\%$ traceable to the NBS.

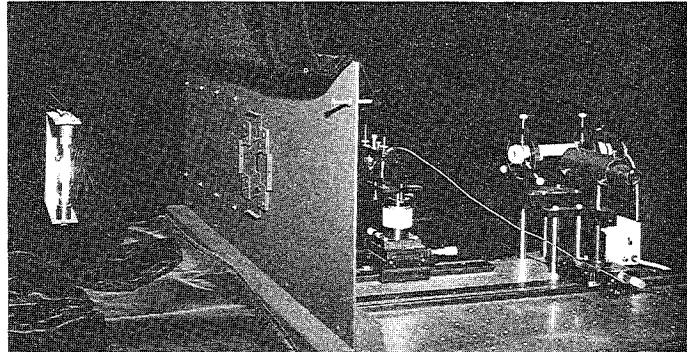

Calibration bench for radiation sensors.

Pyranometer sensors are calibrated against an Eppley Precision Spectral Pyranometer (PSP) under natural daylight conditions. Absolute error under these conditions is $\pm 5\%$ maximum, typically $\pm 3\%$.

A calibration certificate is supplied with every LI-COR sensor. *Recalibration is recommended every two years to assure the highest accuracy in radiation measurement.*

SPECTRAL RESPONSE

Sensor spectral response conformity is designed and tested using a Cary 17D spectrophotometer having a bandwidth of 4 nm or less, and a blackened thermopile-calibrated silicon photodiode. With the Cary 17D the transmittance for over 25 different colored glass filters from various glass manufacturers has been measured and the data stored in memory. A stepwise multilinear regression analysis is then run, using the filter data on

file, which enables the selection of both the glass type and glass thickness to be used in the sensor. This provides for a far superior sensor response curve than the original quantum sensor design.* With this same system, the spectral response of actual sensors can be measured and stored. A spectral response curve is available as an option and can be ordered with any sensor.



The Cary 17D Spectrophotometer (right).

Spectroradiometric data for various sources is also stored in the computer (some through the use of the LI-COR LI-1800 Portable Spectroradiometer). By knowing the sensor spectral response, as well as the spectroradiometric data of a source, one can compute the activity error (or spectral correction) for a given sensor.

Absolute calibrations and spectral responses of LI-COR sensors have been checked by the National Research Council of Canada to insure accuracy and quality of LI-COR calibrations.

*Biggs, W. W., A. R. Edison, J. D. Eastin, K. W. Brown, J. W. Maranville and M. D. Clegg. 1971. Photosynthesis light sensor and meter. *Ecology* 52:125-131.

CONVERSION FACTORS FOR RADIATION DATA

Type of Measurement	Instantaneous Measurements	Full Sun plus Sky	Integrated Measurements	One Day's Integration
Quantum	$1 \mu\text{E s}^{-1} \text{m}^{-2} = 1.0 \mu\text{mol s}^{-1} \text{m}^{-2}$ $= 6.022 \cdot 10^{17} \text{ photons s}^{-1} \text{m}^{-2}$ $= 6.022 \cdot 10^{17} \text{ quanta s}^{-1} \text{m}^{-2}$ $= 6.022 \cdot 10^{13} \text{ quanta s}^{-1} \text{cm}^{-2}$	PPFD $\approx 2000 \mu\text{E s}^{-1} \text{m}^{-2}$	$1 \text{ E m}^{-2} = 1 \text{ mol m}^{-2}$ $= 6.022 \cdot 10^{23} \text{ photons m}^{-2}$ $= 6.022 \cdot 10^{23} \text{ quanta m}^{-2}$	Photosynthetic Photon Exposure $\approx 60 \text{ E m}^{-2}$
Radiometric	$1 \text{ W m}^{-2} = 1.433 \cdot 10^{-3} \text{ cal cm}^{-2} \text{ min}^{-1}$ $= 1.433 \cdot 10^{-3} \text{ langley min}^{-1}$ $= 0.100 \text{ mW cm}^{-2}$ $= 100 \mu\text{W cm}^{-2}$ $= 1.0 \text{ J s}^{-1} \text{m}^{-2}$ $= 1000 \text{ erg s}^{-1} \text{cm}^{-2}$ $= 0.317 \text{ BTU ft}^{-2} \text{ h}^{-1}$ $= 5.283 \cdot 10^{-3} \text{ BTU ft}^{-2} \text{ min}^{-1}$	Total Irradiance $\approx 1000 \text{ W m}^{-2}$ Photosynthetic Irradiance $\approx 500 \text{ W m}^{-2}$ Near IR (745-815 nm) Irradiance $\approx 60 \text{ W m}^{-2}$	$1 \text{ Wh m}^{-2} = 0.0860 \text{ cal cm}^{-2}$ $= 0.0860 \text{ langley}$ $= 0.1 \text{ mWh cm}^{-2}$ $= 100 \mu\text{Wh cm}^{-2}$ $= 3600 \text{ J m}^{-2}$ $= 0.3600 \text{ J cm}^{-2}$ $= 3.600 \cdot 10^6 \text{ erg cm}^{-2}$ $= 0.317 \text{ BTU ft}^{-2}$	Total Radiant Exposure $\approx 8000 \text{ Wh m}^{-2}$ Photosynthetic Radiant Exposure $\approx 4000 \text{ Wh m}^{-2}$ Near (745-815 nm) IR Radiant Exposure $\approx 500 \text{ Wh m}^{-2}$
Photometric	$1 \text{ lux} = 1 \text{ lm m}^{-2}$ $= 0.0929 \text{ lm ft}^{-2}$ $= 0.0929 \text{ footcandle}$ $= 0.001 \text{ klux}$	Illuminance $\approx 100 \text{ klux}$	$1 \text{ lux h} = 0.0929 \text{ footcandle h}$ $= 0.001 \text{ klux h}$	Luminous Exposure $\approx 800 \text{ klux h}$

The values shown for "Full sun plus sky" and "One day's integration" are typical measurements taken mid-summer in Lincoln, Nebraska, USA using cosine type sensors. These values can vary greatly depending on atmospheric conditions, location (including latitude and elevation), time of year, and time of day.

RMR2-1084
Printed in U.S.A.
Copyright © 1979, LI-COR, inc.
All rights reserved.

 **LI-COR, inc. / LI-COR, Ltd.**
Box 4425 / Lincoln, Nebraska 68504 USA
Phone (402) 467-3576 / TWX: 910-621-8116