

Analysis of Methane in Air

GML Technical Procedure

Contents

1. Purpose
2. Scope
3. References
4. Terms and Definitions
5. Procedures
 - 5.1 Gas Handling
 - 5.2 Analysis System
 - 5.3 Quality Control
6. Calculations
 - 6.1 Mole Fraction
 - 6.2 Uncertainties
7. Data Collection and Storage
8. Safety
9. Documentation
10. Appendix

Approved by

Bradley Hall
Division Lead
Long-term Observation of Greenhouse Gases and Ozone-depleting Substances Division
NOAA Global Monitoring Laboratory

Date

Ver.	Effective Date	Authors	Approval	Filename
2.1	April 15, 2024	ED, AMC, TM	AA	TP_analysis_CH4_v2.1.docx

Technical Procedure: Analysis of Methane in Air

1. Purpose

This document provides the technical procedures for the analysis of methane (CH₄) in air by laser spectroscopy.

2. Scope

NOAA/GML provides compressed gas standards to the WMO GAW community. Natural air or modified natural air standards are analyzed for CH₄. Methane dry air mole fractions are determined by laser spectroscopy, relative to the WMO CH₄ X2004A scale, maintained by NOAA. The CH₄ calibration scale is derived from gravimetrically-prepared primary standards (see TP_primary_gravimetry.pdf). The procedures described here only pertain to CH₄ analysis for which a certificate of analysis is issued.

3. References

Dlugokencky E.J., R.C. Myers, P.M. Lang, K.A. Masaire, A. M. Crotwell, K.W. Thoning, B.D. Hall, J.W. Elkins, and L.P. Steele (2005), Conversion of NOAA atmospheric dry air CH₄ mole fractions to a gravimetrically prepared standard scale, *J. Geophys. Res.*, 110, D18306, doi: 10.1029/2005JD006035.

Dlugokencky, E.J., L.P. Steele, P.M. Lang, and K.A. Masarie (1994), The growth rate and distribution of atmospheric methane, *J. Geophys. Res.*, 99, 17,021-17,043.

JCGM (2008), International vocabulary of metrology – Basic and general concepts and associated terms (VIM), JCGM 200:2008.

JCGM 100:2008 Evaluation of Measurement Data – Guide to the Expression of Uncertainty in Measurement (ISO GUM 1995 with minor corrections), Joint Committee for Guides in Metrology (2008); http://www.bipm.org/utis/common/documents/jcgm/JCGM_100_2008_E.pdf

Salameh, P.K., Scripps Institution of Oceanography, Unix-based Integrator and Chromatographic Database, personal communication, 1997.

Tans, P. P., Crotwell, A. M., and Thoning, K. W. (2017), Abundances of isotopologues and calibration of CO₂ greenhouse gas measurements, *Atmos. Meas. Tech.*, 10, 2669-2685, doi: 10.5194/amt-10-2669-2017.

4. Terms and Definitions

Ver.	Effective Date	Authors	Approval	Filename
2.1	April 15, 2024	ED, AMC, TM	AA	TP_analysis_CH4_v2.1.docx

Technical Procedure: Analysis of Methane in Air

analysis system: Includes the laser spectroscopic instruments, associated hardware, and computer used to analyze CH₄ in compressed gas cylinders (synonymous with measuring system).

CRDS: Cavity ring-down spectroscopy.

gas standard: A cylinder of compressed gas with mole fractions assigned by metrological methods or by comparison to higher-level standards, used to characterize the response of an instrument for calibration or quality control purposes. For the purposes of this TP, primary, secondary, and tertiary standards are gas standards.

mole fraction: The ratio of the number of moles of a particular compound to the total number of moles. Dry air mole fraction is the ratio of the number of moles a particular compound to the total number of moles in dry air. Within the scope of this TP, all samples are analyzed for dry air mole fraction.

primary standard: A measurement standard established using a primary reference measurement procedure, or created as an artifact, chosen by convention.

reference cylinder: Dry, natural air in a high-pressure cylinder with near-ambient CH₄ mole fraction used to normalize variations in temperature and pressure through an analysis period.

regulator: A device used to reduce the pressure in a gas cylinder (input) to a lower pressure (output). High-purity and ultra-high purity regulators are used.

response curve: A function that relates the instrument response to amount of substance (mole fraction).

secondary standard: A standard whose value is determined through analysis relative to primary standards, for a quantity of the same kind. These standards are used to calibrate the instrument response. Use of secondary standards for routine calibration prolongs the life of primary standards. For CH₄, values for secondary standards may also be assigned by comparison to other secondary standards, with verification performed by comparison to primaries.

target tank: A target tank is used for routine monitoring of system performance. The system should be capable of reproducing the assigned value of the target tank (within expected uncertainties).

tertiary standard: Measurement standard established through calibration with respect to secondary measurement standards for a quantity of the same kind.

Ver.	Effective Date	Authors	Approval	Filename
2.1	April 15, 2024	ED, AMC, TM	AA	TP_analysis_CH4_v2.1.docx

WMO/GAW: World Meteorological Organization, Global Atmosphere Watch.

5. Procedures

5.1 Gas Handling

Cylinders to be analyzed are stored in a common location and moved to the CH₄ analysis room when needed. Prior to analysis, a regulator is attached. Several regulators models are used. For CH₄, regulator purity is generally not an issue although high purity or ultra-high purity low flow regulators are preferred to preserve the integrity of other trace gases that might be compromised with sub-standard regulators. Upon connecting the regulator, the residual gas in the regulator is purged (flushed) with air from the cylinder. It is left to the analyst to determine the amount of flushing required, as it depends on the history of the regulator and the mole fraction of the gas being analyzed. Typically, four flush cycles and 24 hours of conditioning time are used. The cylinder to be analyzed is connected to one of the sample manifold ports on the analysis system. The delivery pressure on the regulator should be set to approximately 10 – 15 psig. The delivery pressure on the reference cylinder should also be set to 10 - 15 psig.

Small stainless steel water traps are used on the analysis system to prevent subtle cylinder-to-cylinder differences in H₂O. The traps are 1/4" O.D. stainless steel tubes immersed in an ethanol bath maintained at approximately -75 °C (acceptable range of temperature fluctuations for the chiller are -65 to -78 °C).

5.2 Analysis System

The CH₄ analysis system is combined with the CO₂ analysis system and is described in Tans et al. (2017). Briefly, the analysis system uses a cavity ring-down spectroscopy (CRDS) gas analyzer to measure the major isotopologue of CH₄ (¹²C¹H₄). The instruments are calibrated approximately monthly by a suite of 14 secondary standards covering the CH₄ range 390 - 5900 nmol mol⁻¹. Each standard is measured relative to a reference cylinder (see below). Calibration curves fit to the responses of the entire suite of secondary standards, referred to as a response curve, relate CH₄ mole fraction to instrument response (relative to the bracketing reference aliquots). The assigned CH₄ values are based on measurement of only the major isotopologue. Unlike CO₂, differences in CH₄ isotopic composition between the primary and secondary standards and atmospheric CH₄ are small. Therefore, CH₄ can be measured based on the ¹²C¹H₄ isotopologue without introducing significant bias. CH₄ values assigned to the secondary standards come from calibration of the secondary standards by the primary standards in an analogous manner.

Ver.	Effective Date	Authors	Approval	Filename
2.1	April 15, 2024	ED, AMC, TM	AA	TP_analysis_CH4_v2.1.docx

Technical Procedure: Analysis of Methane in Air

The cylinder to be analyzed is compared to a reference cylinder in an alternating, A-B-A-B-A... sequence. The reference cylinder is natural air with CH₄ mole fraction of the local ambient conditions at Niwot Ridge on the day of filling. The reference gas typically closely resembles the remote troposphere. The same reference cylinder is used during instrument calibration episodes and during routine measurement of cylinders to account for slow drift in the analyzers between calibration episodes. The analysis system contains a second instrument to measure the isotopic composition of CO₂ (see CO₂ technical procedures). A 4-port switching valve is used to simultaneously measure reference gas on one analyzer and sample (or standard during calibration episodes) on the other, alternating back and forth (see Fig 1). Each analysis cycle includes a measurement of reference gas and sample gas on both instruments. Each analysis episode should consist of 8 cycles to match the cycles used when constructing the response curves.

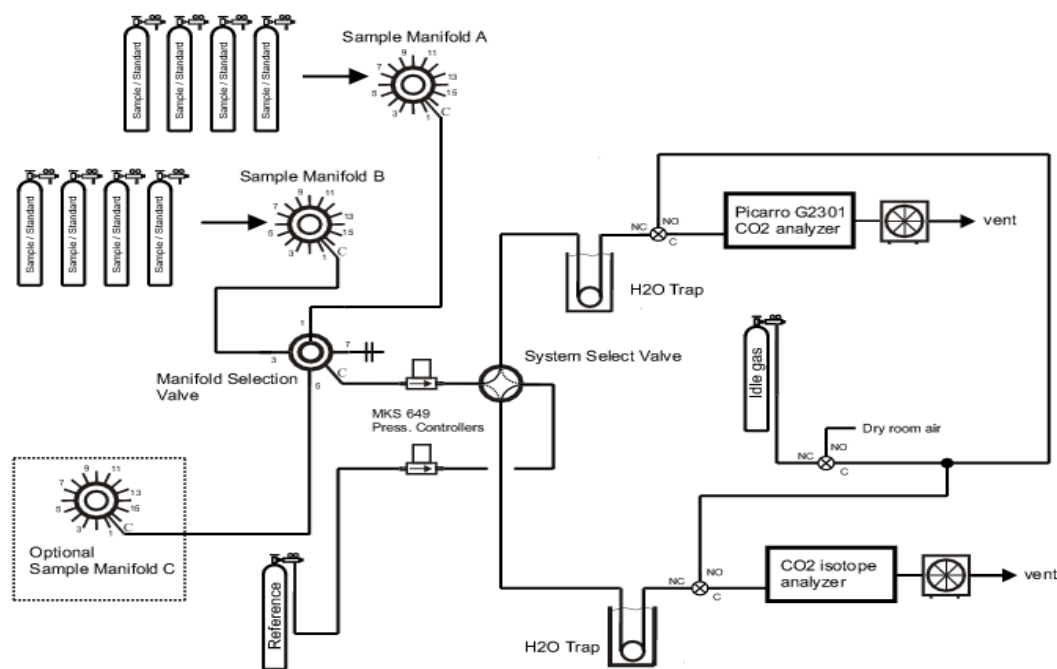

Figure 1: Plumbing diagram of combined CO₂ and CH₄ calibration system.

5.3 Quality Control

Ver.	Effective Date	Authors	Approval	Filename
2.1	April 15, 2024	ED, AMC, TM	AA	TP_analysis_CH4_v2.1.docx

Technical Procedure: Analysis of Methane in Air

It is critical that assignments made using the analytical system are reproducible. For a sample mole fraction that does not change with time, the system must be capable of reproducing the assigned value (within uncertainties) over the long term.

The experienced analyst can easily determine when the system is performing normally. Indicators of performance include, but are not limited to, the spectral fit of the adsorption lines, repeatability of 8 repeat aliquots during the run, and temperature and pressure stability. Short term target tanks are measured approximately bi-weekly, long term target tanks are measured 2-3 times per year. Target tanks are key indicators of system performance (long-term changes in mole fraction due to drift need to be accounted for, but CH₄ has proven to be exceptionally stable in cylinders).

6.0 Calculations

6.1 Mole Fraction

The CH₄ mole fraction in the unknown sample is determined by comparing the instrument response of the unknown sample, relative to the reference tank, to response curves generated once per month during dedicated instrument calibration episodes using the secondary standards. The response of the CRDS instrument is linear within the uncertainty of the primary standards. A linear function is used to relate CH₄ mole fraction to the normalized response ratios.

$$X_{\text{CH}_4} = C_0 + C_1 * R \quad (1)$$

Where C_i are the coefficients of the fit to the secondary standards and R is the instrument response of the sample divided by the average instrument response of the bracketing reference aliquots.

The NOAA CH₄ calibration scale is derived from a suite of gravimetrically-prepared primary standards. The scale was transferred to a set of secondary standards in 2013 - 2015 using the methods described above but with response curves based on the primary standards and using both the CRDS analytical technique and a GC-FID system. Secondary standards are compared to the primary standards every 1-2 years to evaluate the secondary standards for drift and to assess the initial assignments made from the 2013-2015 measurements.

6.2 Uncertainties

Two estimates of uncertainty are reported for each sample. The first is the expanded uncertainty associated with the value assignment (see TP_primary_gravimetry.docx), and is derived from uncertainties in the primary standards that define the scale, scale transfer, and any other

Ver.	Effective Date	Authors	Approval	Filename
2.1	April 15, 2024	ED, AMC, TM	AA	TP_analysis_CH4_v2.1.docx

Technical Procedure: Analysis of Methane in Air

significant uncertainties. Expanded uncertainties are calculated using the GUM (JCGM, 2008) as a guide. The second quantity reported is the long-term reproducibility of the system based on repeated analysis of multiple cylinders (95%ile). Reproducibility is an estimate of our ability to propagate the scale over time periods of several years. It provides an estimate of our ability to detect possible drift in cylinders over time scales of typical use, and is useful for assessing the role of reference materials with respect to inter-laboratory compatibility. Reproducibilities are available on the CCL website: <https://gml.noaa.gov/ccl/refgas.html>.

7.0 Data Collection and Storage

Processed data and metadata are stored on a centrally located computer in a relational database. The raw data (instrument responses) are archived in text files on a networked server. The database is backed up once a day. The raw data server has a full back up every 2 weeks and incremental back ups every work day. The results (processed data) are also available from a web interface and can be accessed by users according to the cylinder serial number.

8.0 Safety

It is NOAA policy to follow safe working practices when handling compressed gas cylinders and laboratory chemicals. Compressed gas cylinders should be secured when analyzed, transported, or stored. Personal protective equipment (PPE) should be used when working with hazardous chemicals or in a high noise environment.

9.0 Documentation

Notes pertaining to cylinder analysis are recorded electronically and saved on the GML server (/ccg/co2/cals/PC1/logs/). For each analysis, the cylinder number and date of analysis should be recorded, along with any variables likely to affect the result. It is left to the analyst to determine which, if any, additional data should be recorded.

Significant notes relating to the performance and maintenance of the analytical system should be recorded using ELOG (an electronic record system).

10.0 Appendix

10.1 Equipment

The following equipment is critical to the functions described in this TP.

Ver.	Effective Date	Authors	Approval	Filename
2.1	April 15, 2024	ED, AMC, TM	AA	TP_analysis_CH4_v2.1.docx

Technical Procedure: Analysis of Methane in Air

Item	Manufacturer	Model Number
CRDS	Picarro	G2301
Offaxis-ICOS	Los Gatos Research, Inc.	CCIA-46-EP
QC-TILDAS	Aerodyne Research, Inc.	QCTILDAS-CS
Pressure controllers	MKS Instruments	649B
Multicool	SP Scientific	MC480A
Valves	Valco	EUDA-24UWE, EUTA-2CSD16MWE, EUTA-2SD4MWE
Solenoid valves	Parker	009-0143-900

10.2 Sample Calculations (mean mole fraction)

Sample calculations are shown here for a typical analysis. Gas type REF is the reference cylinder used to track slow drift between calibration episodes. Gas type SMP is the unknown cylinder. The response curve is determined in a separate mode where the entire suite of standards is run against the reference cylinder. In this instance the response curve is based on the suite of secondary standards with $C_0 = 2.3877$ and $C_1 = 1882.1909$.

Table A1: Example calculations for X_{CH_4}

Response Curve: $X_{CH_4} = 2.3877 + 1882.1909 * R$

Type	Date	Time	Sig	Stddev	N	flag	Resp_Ratio (R)	X_{CH_4}
REF	2018-10-11	10:30:36	1879.734	0.241	10	.		
SMP	2018-10-11	10:33:39	1847.315	0.219	10	.	0.9827	1852.04
REF	2018-10-11	10:36:43	1879.893	0.188	10	.		
SMP	2018-10-11	10:39:48	1847.276	0.143	10	.	0.9826	1851.85
REF	2018-10-11	10:42:50	1880.038	0.173	10	.		
SMP	2018-10-11	10:45:54	1847.639	0.147	10	.	0.9828	1852.22
REF	2018-10-11	10:48:58	1879.883	0.153	10	.		
SMP	2018-10-11	10:52:02	1847.396	0.253	10	.	0.9827	1852.07
REF	2018-10-11	10:55:05	1879.844	0.210	10	.		
SMP	2018-10-11	10:58:10	1847.251	0.158	10	.	0.9827	1852.07
REF	2018-10-11	11:01:14	1879.589	0.273	10	.		
SMP	2018-10-11	11:04:18	1847.284	0.204	10	.	0.9827	1852.06
REF	2018-10-11	11:07:22	1879.942	0.152	10	.		
SMP	2018-10-11	11:10:25	1847.349	0.227	10	.	0.9827	1851.96
REF	2018-10-11	11:13:28	1879.913	0.214	10	.		
SMP	2018-10-11	11:16:32	1847.434	0.178	10	.	0.9827	1852.06
			Mean				0.9827	1852.04
			Standard deviation				0.0001	0.10

Ver.	Effective Date	Authors	Approval	Filename
2.1	April 15, 2024	ED, AMC, TM	AA	TP_analysis_CH4_v2.1.docx

Technical Procedure: Analysis of Methane in Air

Ver.	Effective Date	Authors	Approval	Filename
2.1	April 15, 2024	ED, AMC, TM	AA	TP_analysis_CH4_v2.1.docx