

## Analysis of Carbon Dioxide in Air

GML Technical Procedure

### Contents

1. Purpose
2. Scope
3. References
4. Terms and Definitions
5. Procedures
  - 5.1 Gas Handling
  - 5.2 Analysis System
  - 5.3 Quality Control
6. Calculations
  - 6.1 Mole Fraction
  - 6.2 Uncertainties
7. Data Collection and Storage
8. Safety
9. Documentation
10. Appendix

Approved by

---

Isaac Vimont  
CCL QMS Lead  
Long-term Observation of Greenhouse Gases and Ozone-depleting Substances Division  
NOAA Global Monitoring Laboratory

Date

Version	Effective Date	Authors	Approval	Filename
2.2.0	Jun. 8, 2026	AMC	IV	TP_analysis_CO2_v2.2.0.docx

### 1. Purpose

This document provides the technical procedures for analysis of carbon dioxide (CO<sub>2</sub>) in air by laser spectroscopy. The laser spectroscopic analysis system propagates the CO<sub>2</sub> in air scale, as defined by the manometric system, to standards at lower levels of the calibration hierarchy with high precision to minimize scale transfer uncertainty.

### 2. Scope

NOAA/GML provides compressed gas standards (reference materials) to the World Meteorological Organization/Global Atmosphere Watch (WMO/GAW) community. Natural air or modified natural air gas standards (tertiary standards) are analyzed for CO<sub>2</sub>. Carbon Dioxide dry air mole fractions are determined by laser spectroscopy, relative to the WMO CO<sub>2</sub> mole fraction scale. The WMO CO<sub>2</sub> mole fraction scale is defined by 19 primary standards whose assigned values come from repeated (approximately every 2-3 years) manometric determinations (see TP\_primary\_manometer). The scale is transferred to secondary standards and hence to tertiary standards by laser spectroscopy. The procedures described here only pertain to CO<sub>2</sub> analysis for which a certificate of analysis is issued.

### 3. Informative References

Hall, B. D., Crotwell, A. M., Kitzis, D. R., Mefford, T., Miller, B. R., Schibig, M. F., and Tans, P. P. (2021), Revision of the World Meteorological Organization Global Atmosphere Watch (WMO/GAW) CO<sub>2</sub> calibration scale, *Atmos. Meas. Tech.*, 14, 3015-3032, <https://doi.org/10.5194/amt-14-3015-2021>.

JCGM (2008), International vocabulary of metrology — Basic and general concepts and associated terms (VIM), JCGM 200:2008.

JCGM 100:2008 Evaluation of Measurement Data – Guide to the Expression of Uncertainty in Measurement (ISO GUM 1995 with minor corrections), Joint Committee for Guides in Metrology (2008); [http://www.bipm.org/utis/common/documents/jcgm/JCGM\\_100\\_2008\\_E.pdf](http://www.bipm.org/utis/common/documents/jcgm/JCGM_100_2008_E.pdf)

Tans, P. P., Crotwell, A. M., and Thoning, K. W. (2017), Abundances of isotopologues and calibration of CO<sub>2</sub> greenhouse gas measurements, *Atmos. Meas. Tech.*, 10, 2669-2685, doi:10.5194/amt-10-2669-2017.

Version	Effective Date	Authors	Approval	Filename
2.2.0	Jun. 8, 2026	AMC	IV	TP_analysis_CO2_v2.2.0.docx

#### 4. Terms and Definitions

- **Analysis System:** Includes the laser spectroscopic instruments, associated hardware, and computer used to analyze CO<sub>2</sub> in compressed gas cylinders (synonymous with measuring system).
- **CRDS:** Cavity ring-down spectroscopy.
- **Gas Standard:** A cylinder of compressed gas with mole fractions assigned by metrological methods or by comparison to higher-level standards, used to characterize the response of an instrument for calibration or quality control purposes. For the purposes of this TP, primary, secondary, and tertiary standards are gas standards.
- **Mole Fraction:** The ratio of the number of moles of analyte to the total number of moles. Dry air mole fraction is the ratio of the number of moles of analyte to the total number of moles in dry air. Within the scope of this TP, all samples are analyzed for dry air mole fraction.
- **NDIR:** Non-dispersive infrared spectroscopy.
- **Offaxis-ICOS:** Off-axis integrated cavity output spectroscopy.
- **Primary Standard:** A measurement standard established using a primary reference measurement procedure, or created as an artifact, chosen by convention. CO<sub>2</sub> primary standards are aluminum cylinders containing dry natural air or modified natural air. The CO<sub>2</sub> mole fraction has been determined by manometric determinations (see TP\_primary\_manometer).
- **QC-TILDAS:** Quantum cascade tunable infrared laser differential absorption spectroscopy.
- **Reference Cylinder:** Cylinder of dry, natural air with near-ambient CO<sub>2</sub> mole fraction used to normalize variations in temperature and pressure through an analysis period.
- **Reference Material:** A material, sufficiently homogeneous and stable with respect to one or more specified properties, which has been established to be fit for its intended use in a measurement process. (JCGM 200:2008, 3.6)
- **Regulator:** A device used to reduce the pressure in a gas cylinder (input) to a lower pressure (output) during use. High-purity and ultra-high purity regulators are used.
- **Response Curve:** A function that relates the instrument response to amount of substance (mole fraction).

Version	Effective Date	Authors	Approval	Filename
2.2.0	Jun. 8, 2026	AMC	IV	TP_analysis_CO2_v2.2.0.docx

- **Secondary Standard:** A standard whose value is determined through analysis relative to primary standards, for a quantity of the same kind. These standards are used to calibrate the instrument response. Use of secondary standards for routine calibration prolongs the life of primary standards.
- **Target Tank:** A tertiary standard used for routine monitoring of system performance. The system should be capable of reproducing the assigned value of the target tank (within expected uncertainties).
- **Tertiary Standard:** A standard whose value is determined through analysis relative to secondary standards, for a quantity of the same kind.
- **WMO/GAW:** World Meteorological Organization, Global Atmosphere Watch.

## 5. Procedures

### 5.1 Gas Handling

Cylinders to be analyzed are stored in a common location and moved to the CO<sub>2</sub> analysis room when needed. Prior to analysis, a regulator is attached. Several regulator models are used. For CO<sub>2</sub>, high purity or ultra-high purity models are preferred to preserve the integrity of the gas. Upon connecting the regulator, the residual gas in the regulator is purged (flushed) with air from the cylinder. The analyst determines the amount of flushing and conditioning time required, as it depends on the history of the regulator and the mole fraction of the gas being analyzed. Typically, four flush cycles and 24 hours of conditioning time are used. The cylinder to be analyzed is connected to one of the sample manifold ports on the analysis system. The delivery pressure on the regulator should be set to approximately 10 – 15 psig. The delivery pressure on the reference cylinder should also be set to 10 - 15 psig.

Small stainless steel water traps are used on the analysis system to prevent subtle cylinder to cylinder differences in H<sub>2</sub>O. The traps are 1/4" O.D. stainless steel tubes immersed in an ethanol bath maintained at approximately -70 °C (acceptable range of temperature fluctuations for the chiller are -65 to -78 °C).

### 5.2 Analysis System

The CO<sub>2</sub> analysis system is described in Tans et al. (2017). Briefly, the analysis system uses two laser spectroscopic gas analyzers to measure the three major isotopologues of CO<sub>2</sub> (<sup>16</sup>O<sup>12</sup>C<sup>16</sup>O, <sup>16</sup>O<sup>13</sup>C<sup>16</sup>O, <sup>18</sup>O<sup>12</sup>C<sup>16</sup>O) individually. A CRDS instrument is used to measure <sup>16</sup>O<sup>12</sup>C<sup>16</sup>O together with either an Offaxis-ICOS or QC-TILDAS instrument for <sup>16</sup>O<sup>13</sup>C<sup>16</sup>O and <sup>18</sup>O<sup>12</sup>C<sup>16</sup>O. The Offaxis-ICOS and QC-TILDAS instruments give similar performance and serve as backups for

Version	Effective Date	Authors	Approval	Filename
2.2.0	Jun. 8, 2026	AMC	IV	TP_analysis_CO2_v2.2.0.docx

## Technical Procedure: Analysis of Carbon Dioxide in Air

---

each other as only one is installed at any given time. They are collectively referred to as the isotope analyzer in this document.

The instruments are calibrated approximately every 2-4 weeks by a suite of 16 secondary standards covering the nominal CO<sub>2</sub> range 250 – 800 μmol mol<sup>-1</sup>. Each standard is measured relative to a reference cylinder (see below). The assigned total CO<sub>2</sub> of the standards is decomposed into component isotopologues mole fractions using assigned δ<sup>13</sup>C and δ<sup>18</sup>O of CO<sub>2</sub> values and the method described by Tans et al. (2017). Calibration curves fit to the responses of the entire suite of secondary standards, referred to as response curves, relate mole fraction of each isotopologues to instrument response (relative to the bracketing reference aliquots). Total CO<sub>2</sub> values assigned to the secondary standards come from calibration of the secondary standards by the primary standards in an analogous manner. The δ<sup>13</sup>C and δ<sup>18</sup>O assigned values for the secondary standards come from measurement by the Stable Isotope Laboratory at the Institute of Arctic and Alpine Research, University of Colorado, Boulder. The resulting individual isotopologues specific abundances of the samples are then combined into total CO<sub>2</sub>, δ<sup>13</sup>C, and δ<sup>18</sup>O values accounting for the rare unmeasured isotopologues following Tans et al. (2017).

The cylinder to be analyzed is compared to a reference cylinder in an alternating, A-B-A-B-A... sequence. The reference cylinder is natural air with CO<sub>2</sub> mole fraction of the local ambient conditions at Niwot Ridge on the day of filling. The reference gas typically closely resembles the remote troposphere. The same reference cylinder is used during instrument calibration episodes and during routine measurement of cylinders to account for slow drift in the analyzers between calibration episodes. A 4-port switching valve is used to simultaneously measure a reference gas on one analyzer and a sample (or standard during calibration episodes) on the other, alternating back and forth (see Fig. 1). Each analysis cycle includes a measurement of reference gas and sample gas on both instruments. Each analysis episode should consist of 8 cycles to match the cycles used when constructing the response curves.

Version	Effective Date	Authors	Approval	Filename
2.2.0	Jun. 8, 2026	AMC	IV	TP_analysis_CO2_v2.2.0.docx

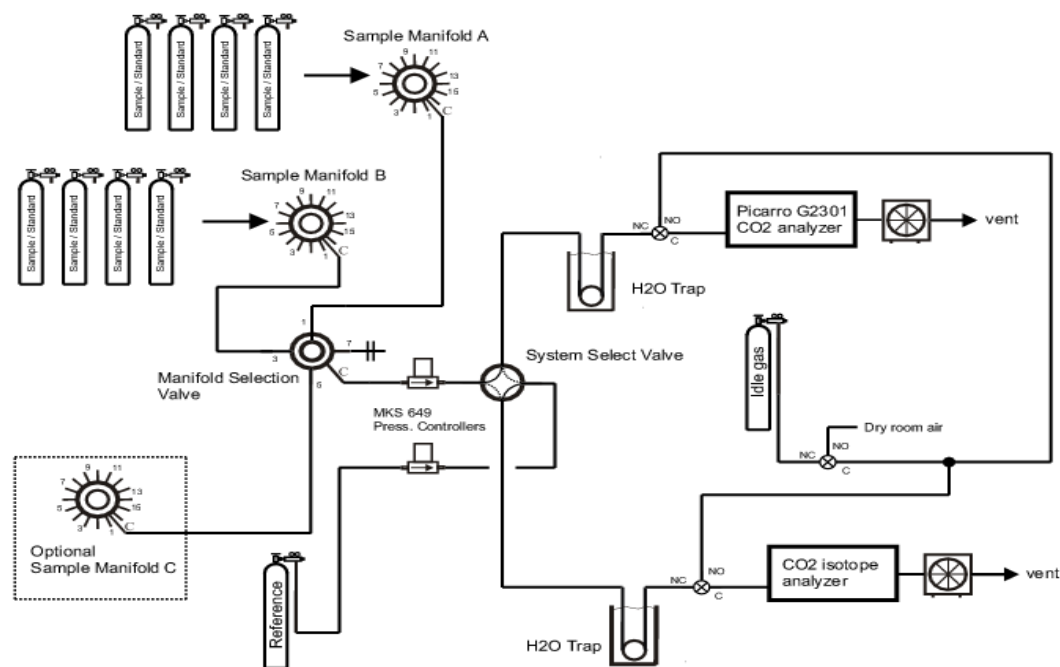

Figure 1: Plumbing diagram of CO<sub>2</sub> calibration system.

### 5.3 Quality Control

It is critical that assignments made using the analytical system are reproducible. For a sample mole fraction that does not change with time, the system must be capable of reproducing the assigned value (within uncertainties) over the long term.

The experienced analyst can easily determine when the system is performing normally. Indicators of performance include, but are not limited to, the spectral fit of the adsorption lines, repeatability of 8 repeat aliquots during the run, and temperature and pressure stability. Short term target tanks are measured approximately bi-weekly, long term target tanks are measured 1-2 times per year. Target tanks are key indicators of system performance, assuming long-term changes in mole fraction due to drift are known.

Version	Effective Date	Authors	Approval	Filename
2.2.0	Jun. 8, 2026	AMC	IV	TP_analysis_CO2_v2.2.0.docx

## 6.0 Calculations

### 6.1 Mole Fraction

The mole fraction of CO<sub>2</sub> in an unknown sample is determined by comparing the instrument response of the unknown sample to that of a suite of standards using CCL procedures as described in TP\_analysis\_calculations with the following exceptions.

The amount fraction of the three major isotopologues of CO<sub>2</sub> in the unknown sample are determined by comparing the instrument responses (for each isotopologue) of the unknown sample, relative to the reference tank, to isotopologue-specific response curves.

The isotopologue-specific mole fractions determined for the unknown are converted into total CO<sub>2</sub>,  $\delta^{13}\text{C}$ , and  $\delta^{18}\text{O}$  values, accounting for the unmeasured rare isotopologues, using the method from Tans et al. (2017). The total CO<sub>2</sub>,  $\delta^{13}\text{C}$ , and  $\delta^{18}\text{O}$  values are saved in the SQL database. Isotopologue-specific mole fractions are not saved, but can be regenerated.

### 6.2 Uncertainties

Two estimates of uncertainty are reported for each sample. The first is the expanded uncertainty associated with the value assignment (see TP\_primary\_manometer), and is derived from uncertainties in the primary standards that define the scale, scale transfer, and any other significant uncertainties. Expanded uncertainties are calculated using the GUM (JCGM, 2008) as a guide.

The second term, referred to as scale transfer uncertainty, is the uncertainty of the measurement relative to the defined scale. This quantity is the relevant uncertainty estimate to use when propagating uncertainties to atmospheric measurements and comparing to other measurements traceable to the WMO scale.

The scale transfer uncertainty of a calibration episode, referred to as "episode uncertainty" in data distributions, and resulting value assignment is calculated using common CCL procedures as described in TP\_analysis\_calculations.

## 7.0 Data Collection and Storage

The sample tank information (port number, serial number, pressure, and regulator) is either entered manually at the start of the analysis or read directly from the refgas manager DB tables by using the CO<sub>2</sub> "to-do" lists.

Data are stored in both raw format (raw instrument response and quality control metadata) on a centrally located computer server and in processed forms (total CO<sub>2</sub>,  $\delta^{13}\text{C}$ , and  $\delta^{18}\text{O}$ ) in a

Version	Effective Date	Authors	Approval	Filename
2.2.0	Jun. 8, 2026	AMC	IV	TP_analysis_CO2_v2.2.0.docx

## Technical Procedure: Analysis of Carbon Dioxide in Air

---

relational database to facilitate efficient data processing and quality control. The database is backed up once a day and the raw data server has a full back-up every two weeks with daily incremental back-ups.

Mole fractions and isotopic values assigned to primary and secondary standards are stored in a MySQL database, and retrieved by the processing program.

### 8.0 Safety

It is GML policy to follow safe working practices when handling compressed gas cylinders and laboratory chemicals. Compressed gas cylinders should be secured when analyzed, transported, or stored. Personal protective equipment (PPE) should be used when working with hazardous chemicals or in a high noise environment.

### 9.0 Documentation

Notes pertaining to cylinder analysis are recorded electronically and saved on the GML server (/ccg/co2/cals/PC1/logs/). For each analysis, the cylinder number, date, and time of analysis should be recorded, along with any variables likely to affect the result. The analyst determines which, if any, additional data should be recorded.

Significant notes relating to the performance and maintenance of the analytical system should be recorded using ELOG (an electronic record system).

### 10.0 Appendix

#### 10.1 Equipment

The following equipment is critical to the functions described in this TP.

Item	Manufacturer	Model Number
CRDS	Picarro	G2301
Offaxis-ICOS	Los Gatos Research, Inc.	CCIA-46-EP
QC-TILDAS	Aerodyne Research, Inc.	QCTILDAS-CS
Pressure controllers	MKS Instruments	649B
Multicool	SP Scientific	MC480A
Valves	Valco	EUDA-24UWE, EUTA-2CSD16MWE, EUTA-2SD4MWE
Solenoid valves	Parker	009-0143-900

Version	Effective Date	Authors	Approval	Filename
2.2.0	Jun. 8, 2026	AMC	IV	TP_analysis_CO2_v2.2.0.docx

## 10.2 Sample Calculations (Mean Mole Fraction)

Sample calculations are shown here for a typical analysis. Gas type REF is the reference cylinder used to track slow drift between calibration episodes. Gas type SMP is the unknown cylinder. This example is for the  $^{16}\text{O}^{12}\text{C}^{16}\text{O}$  isotopologues mole fraction, X(626). The response curve is determined in a separate mode where the entire suite of standards is run against the reference cylinder. In this instance the response curve for the  $^{16}\text{O}^{12}\text{C}^{16}\text{O}$  isotopologues follows equation (1) with  $c_0 = 0.18436648$  and  $c_1 = 395.56334783$ .

**Table A1: Example calculations for X(626)**

$$X(626) = 0.18436648 + 395.56334783 * R$$

Type	Date	Time	Sig	Sig_sd	N	Flag	Resp_Ratio (R)	X(626)
REF	2017 01 24	11:35:23	399.7326	0.0152	10	.		
SMP	2017 01 24	11:38:27	390.6285	0.0142	10	.	0.977196045	386.727
REF	2017 01 24	11:41:32	399.7559	0.0127	10	.		
SMP	2017 01 24	11:44:35	390.6413	0.0141	10	.	0.977208386	386.732
REF	2017 01 24	11:47:39	399.7487	0.0114	10	.		
SMP	2017 01 24	11:50:42	390.6465	0.0127	10	.	0.977194138	386.727
REF	2017 01 24	11:53:46	399.7782	0.0080	10	.		
SMP	2017 01 24	11:56:49	390.6461	0.0067	10	.	0.977192038	386.726
REF	2017 01 24	11:59:53	399.7496	0.0101	10	.		
SMP	2017 01 24	12:02:56	390.6503	0.0087	10	.	0.977210122	386.733
REF	2017 01 24	12:05:59	399.7720	0.0141	10	.		
SMP	2017 01 24	12:09:02	390.6477	0.0111	10	.	0.977191518	386.726
REF	2017 01 24	12:12:05	399.7595	0.0094	10	.		
SMP	2017 01 24	12:15:08	390.6520	0.0132	10	.	0.97719213	386.726
REF	2017 01 24	12:18:12	399.7803	0.0108	10	.		
SMP	2017 01 24	12:21:16	390.6662	0.0101	10	.	0.977202228	386.730
Mean							0.977198326	386.728
Standard Deviation							0.000007584	0.003

Similar calculations are used for  $^{16}\text{O}^{13}\text{C}^{16}\text{O}$  and  $^{18}\text{O}^{12}\text{C}^{16}\text{O}$  isotopologues mole fractions using equations (2) and (3). The resulting isotopologue specific values (X(626), X(636), and X(826)) are combined into total  $\text{CO}_2$ ,  $\delta^{13}\text{C}$ , and  $\delta^{18}\text{O}$  values, which are stored and reported to users. The derivation of the equations used for this is beyond the scope of this TP, the reader is referred to Tans et al. (2017) for details.

Version	Effective Date	Authors	Approval	Filename
2.2.0	Jun. 8, 2026	AMC	IV	TP_analysis_CO2_v2.2.0.docx

## Technical Procedure: Analysis of Carbon Dioxide in Air

---

Version	Effective Date	Authors	Approval	Filename
2.2.0	Jun. 8, 2026	AMC	IV	TP_analysis_CO2_v2.2.0.docx