

## Determination of CO<sub>2</sub> in Air Using the NOAA Manometer

Global Monitoring Laboratory (GML) Technical Procedure

### Contents

1. Purpose
2. Scope
3. References
4. Terms and Definitions
5. Procedures
  - 5.1 Cylinder Storage
  - 5.2 Gas Handling
  - 5.3 Manometer Operation
  - 5.4 Traceability
6. Calculations
  - 6.1 Mole Fraction
  - 6.2 Volume Ratio
  - 6.3 Manometer Data
  - 6.4 Uncertainties
7. CO<sub>2</sub> Calibration Scale
8. Safety
9. Documentation
10. Appendix

Approved by

---

Isaac Vimont

Date

CCL QMS Lead

Long-term Observation of Greenhouse Gases and Ozone-depleting Substances Division

NOAA Global Monitoring Laboratory

Version	Effective Date	Authors	Approval	Filename
2.2.0	June 8, 2026	AMC	IV	TP_primary_manometer_v2.2.0.doc

## 1. Purpose

This document provides the technical procedure for the determination of carbon dioxide (CO<sub>2</sub>) in air using the NOAA manometer. Dry-air mole fractions of CO<sub>2</sub> are traceable to the SI-derived quantity amount of substance fraction. CO<sub>2</sub> mole fractions are determined by measurement of SI quantities mass, temperature, time, and length.

## 2. Scope

This document provides general procedures for the measurement of CO<sub>2</sub> primary standards. The NOAA manometer is the principal method for determining the CO<sub>2</sub> mole fractions in CO<sub>2</sub> primary standards. The primary standards are used to assign mole fractions to secondary standards via scale transfer using laser spectroscopic methods. Detailed descriptions of the manometer and manometric method are given by Zhao et al. (1997) and Hall et al. (2021).

## 3. Informative References

Hall B. D., A. Crotwell, D. R. Kitzis, T. Mefford, B. R. Miler, M, F. Schibig, and P. P. Tans, Revision of the WMO-GAW CO<sub>2</sub> mole fraction scale, *Atmospheric Measurement Techniques*, 14, 4, 3015-3032, 10.5194/amt-14-3015-2021

JCGM (2012), International vocabulary of metrology — Basic and general concepts and associated terms (VIM), JCGM 200:2012 (JCGM 200:2008 with minor corrections).

JCGM 100:2008 Evaluation of Measurement Data – Guide to the Expression of Uncertainty in Measurement (ISO GUM 1995 with minor corrections), Joint Committee for Guides in Metrology (2008);  
[http://www.bipm.org/utis/common/documents/jcgm/JCGM\\_100\\_2008\\_E.pdf](http://www.bipm.org/utis/common/documents/jcgm/JCGM_100_2008_E.pdf)

Sengers, J. M, H.L. Klien, and J. S. Gallagher, Pressure-volume-temperature relations of gases; virial coefficients, Report AEDC-TR-71-39, Heat Division, National Bureau of Standards, Gaithersburg, MD., 1971.

Tans, P. P., Crotwell, A. M., and Thoning, K. W. (2017), Abundances of isotopologues and calibration of CO<sub>2</sub> greenhouse gas measurements, *Atmos. Meas. Tech.*, 10, 2669-2685, doi: 10.5194/amt-10-2669-2017.

Zhao, C. L., P. P. Tans, and K. W. Thoning, (1997), A high precision manometric system for absolute calibrations of CO<sub>2</sub> in dry air, *J. Geophys. Res.*, 102, D5, pp. 5885-5894.

Version	Effective Date	Authors	Approval	Filename
2.2.0	June 8, 2026	AMC	IV	TP_primary_manometer_v2.2.0.doc

Zhao, C. L. and Tans, P. P. (2006), Estimating the uncertainty of the WMO mole fractions scale for carbon dioxide, *J. Geophys. Res.*, *111*, D08S09, doi:10.1029/2005JD0060003.

#### 4. Terms and Definitions

**Large volume (LV):** A glass volume of approximately 6 L, located inside a temperature-controlled oven.

**Manometer:** A device used to determine the mole fraction of CO<sub>2</sub> in air. The manometer consists of two glass volumes (SV and LV), a glass vacuum manifold for separating CO<sub>2</sub> from other components in air, various valves, pressure transducers, and temperature sensors, and a temperature-controlled oven.

**Mole fraction:** The ratio of the number of moles of a particular compound to the total number of moles. Dry air mole fraction is the ratio of the number of moles a particular compound to the total number of moles in dry air. Within the scope of this TP, all samples are analyzed for dry air mole fraction.

**NDIR:** Non-Dispersive Infra-Red (analyzer).

**Primary calibration episode:** The period during which WMO/GAW primary standards are analyzed using the manometer (normally 6-12 months duration).

**Primary standard:** A measurement standard established using a primary reference measurement procedure, or created as an artifact, chosen by convention. For GML, CO<sub>2</sub> primary standards are aluminum high pressure cylinders containing dry air, for which the CO<sub>2</sub> mole fraction has been determined using the manometer.

**Small volume (SV):** A glass volume of approximately 7 ml, located inside a temperature-controlled oven.

**Volume ratio:** Ratio of volumes (LV/SV).

#### 5. Procedures

##### 5.1 CO<sub>2</sub> Primary Standards

CO<sub>2</sub> primary standards are intended for long-term use, stored in a secure location, and used sparingly to transfer the CO<sub>2</sub> scale to secondary standards. The WMO CO<sub>2</sub>-in-air scale is defined by the analysis of what comes out of each cylinder, over a range of mole fractions. This is different from most calibration scales for gas mixtures which are defined by the amounts of the

Version	Effective Date	Authors	Approval	Filename
2.2.0	June 8, 2026	AMC	IV	TP_primary_manometer_v2.2.0.doc

components of a mixture originally put into a cylinder. CO<sub>2</sub> mole fractions are determined using the manometer approximately every three years. The timing of manometer measurements is not critical, but repeated measurements are necessary to assess drift, and allows for an improving definition of the scale over time. Additional methods can also be used to study long-term drift, such as comparison of primary standards to each other and against other well-characterized samples using instruments with sufficient stability and repeatability to provide useful information.

### 5.2 Gas Handling

Prior to analysis, a primary standard is moved to the manometer laboratory. Regulators are normally left attached to reduce gas usage during flushing and conditioning. It is left to the analyst to determine that the regulator connection is leak-free, and that the regulator volume is sufficiently flushed.

### 5.3 Manometer Operation

The theory behind the manometer is that the mole fraction of CO<sub>2</sub> in an air sample can be determined by measuring the pressure and temperature of nearly pure CO<sub>2</sub> in a known volume extracted from the sample, and the pressure and temperature of the air sample in a larger volume prior to extraction. The two volumes need not be known absolutely, as long as the ratio of volumes can be determined.

The manometer consists of a glass manifold with computer-controlled valves, a vacuum pump, a data acquisition system, and calibrated high-precision pressure and temperature sensors. A computer program controls the evacuation of the manifold and filling of sample volumes with sample gas. CO<sub>2</sub> is extracted from a large glass volume (LV), cryogenically purified to separate CO<sub>2</sub> from other atmospheric constituents, including water vapor, and cryogenically transferred to a small glass volume (SV).

The steps in the procedure are as follows:

- 1) A gas cylinder (sample gas) is connected to an inlet port.
- 2) The regulator is flushed several times to purge room air and checked for leaks.
- 3) The “PREPARE” program is executed, during which:
  - a. The manometer is evacuated.
  - b. The large volume (LV) is filled with sample gas and allowed to equilibrate for several hours (3-4 hours is usually sufficient). (note 1)

Version	Effective Date	Authors	Approval	Filename
2.2.0	June 8, 2026	AMC	IV	TP_primary_manometer_v2.2.0.doc

## Technical Procedure: Determination of CO<sub>2</sub> in Air Using the NOAA Manometer

---

- 4) The “MANO” program is executed to perform a manometric measurement, during which:
- a. The manometer is evacuated.
  - b. The LV is filled with sample gas.
  - c. The LV is flushed with sample gas for a few minutes.
  - d. The CO<sub>2</sub> in the sample gas is measured continuously by an NDIR analyzer, both by flushing gas through the LV and by diverting gas directly to the analyzer (bypassing the LV). This is a quality control indicator. If the CO<sub>2</sub> mole fractions differ, it is likely that the surfaces in the manometer have not reached equilibrium and the manometer needs to be evacuated and re-filled. The amount of CO<sub>2</sub> difference that can be tolerated is a matter of experience and is left to the analyst.
  - e. After filling the LV and allowing for stabilization (~5 min.), the pressure and temperature are measured and recorded.
  - f. After evacuating the extraction manifold, CO<sub>2</sub> is cryogenically extracted from the sample in the LV. Flow and pressure are controlled to extract all CO<sub>2</sub> while preventing condensation of liquid oxygen. This is a multi-stage process designed to separate CO<sub>2</sub> from other constituents, including water vapor.
  - g. The purified CO<sub>2</sub> is cryogenically transferred to the small volume (SV).
  - h. The CO<sub>2</sub> is allowed to vaporize (liquid nitrogen is removed from SV).
  - i. The pressure and temperature of the SV are measured and recorded as the temperature of the oven stabilizes. Data should be collected for at least 30 minutes to ensure that the temperature equilibration of the SV is observed. Temperature equilibrium normally occurs approximately 15 minutes after the liquid nitrogen has been removed from the SV.
- 5) After the experiment is complete, the manometer is flushed and evacuated to prepare for the next analysis using the “FLUSH” program

Notes: (1) We have found that repeatability improves when the PREPARE step is run twice: once during the night before a planned run, and once during the morning of the planned run.

Version	Effective Date	Authors	Approval	Filename
2.2.0	June 8, 2026	AMC	IV	TP_primary_manometer_v2.2.0.doc

## 5.4 Traceability

Instruments critical to the manometer operation are calibrated by an accredited (ISO 17025, ISO-9001, NVLAP, A2LA) calibration and testing laboratory. Items critical to manometer operation include four temperature sensors and a corresponding data interface, the Paroscientific pressure sensor, and the piston, mass set, and vacuum gauge associated with the piston gauge (see Appendix 10.2). The calibration interval is not specified because it depends on the manometer workload. It is preferred, but not always practical, to send devices for calibration prior to measuring the suite of primary standards. In the event that the manometer is used prior to full calibration, data should be stored in a manner that allows reprocessing using updated coefficients.

The pressure sensor is calibrated in-house, at intervals determined by the analyst, using a dead weight piston gauge. A secondary pressure standard (Fluke RPM4) is used to check the stability of the pressure calibration. At a minimum, the pressure sensor should be calibrated several times during a period in which primary standards are analyzed. The analyst determines suitable calibration coefficients for the pressure sensor, and how they might change with time.

Although the volume ratio is a fixed physical quantity, it is recommended that the volume ratio be confirmed by experiment before and during the primary calibration episode. The volume ratio is measured by successive expansions of air or N<sub>2</sub> into progressively larger volumes bridging the volume difference between the SV and LV. Care should be taken to ensure that the volume ratio remains constant during a primary calibration episode: the physical state of the manometer (connections, glassware, valves, etc.), should not be altered during a primary calibration episode unless necessary. Any alteration of the physical state of the manometer should be followed by a rigorous assessment of the volume ratio.

Between external calibrations of equipment, experiments can be performed to evaluate the performance of critical elements. These include, but are not limited to:

- comparison of all temperature probes in a common location in the manometer oven
- comparison of multiple vacuum gauges
- comparison of the main pressure sensor with other high-quality sensors
- testing the sensitivity of the system to errors in various devices
- measurement of several well-characterized samples to aid in assessing performance of the entire system

## 6. Calculations

### 6.1 Dry Air Mole Fraction

The mole fraction of CO<sub>2</sub> is determined from the measured pressure, temperature, and volume of the extracted CO<sub>2</sub> (SV) and the measured pressure, temperature, and volume of the air sample

Version	Effective Date	Authors	Approval	Filename
2.2.0	June 8, 2026	AMC	IV	TP_primary_manometer_v2.2.0.doc

## Technical Procedure: Determination of CO<sub>2</sub> in Air Using the NOAA Manometer

---

(LV). Because N<sub>2</sub>O is not separated from CO<sub>2</sub> during the extraction step, the N<sub>2</sub>O will be present in the purified CO<sub>2</sub>. The measurement result is calculated as:

$$X_{CO_2} = (\phi^{-1}) \frac{P_{CO_2} T_{air}}{P_{air} T_{CO_2}} (1 + A_1 - A_2) - X_{N_2O} + X_{CO_2_{loss}} \quad (1)$$

$$A_1 = \frac{P_{air} \beta_{air}}{RT_{air}}$$

$$A_2 = \frac{P_{CO_2} \beta_{CO_2}}{RT_{CO_2}}$$

where  $T$  and  $P$  are the temperatures and pressures of the large volume (air) and small volume (CO<sub>2</sub>),  $\beta_{air}$  and  $\beta_{CO_2}$  are second Virial coefficients,  $R$  is the gas constant,  $\Phi$  is the volume ratio,  $X_{N_2O}$  is the mole fraction of N<sub>2</sub>O in the air sample, and  $X_{CO_2_{loss}}$  is a correction needed to account for loss of CO<sub>2</sub> to Viton o-rings in the small volume from time  $t=0$  to the time at which  $X_{CO_2}$  is to be determined.  $X_{CO_2_{loss}}$  is determined from the rate of change of calculated  $X_{CO_2}$  (ppm/min) and the elapsed time between the start of data collection and the final averaging period (typically ~20 minutes). For a typical measurement at 400 ppm CO<sub>2</sub>,  $X_{N_2O}$  is 0.33 ppm and  $X_{CO_2_{loss}}$  is ~0.25 ppm (see Appendix 10.4). The magnitude of  $X_{CO_2_{loss}}$  depends on the mole fraction of CO<sub>2</sub> and the amount of time the sample is held in the small volume. Equation 1 is an alternate form of eq. 8 from Zhao and Tans (1997).

### 6.2 Volume Ratio

The volume ratio is measured by successive expansions of air or N<sub>2</sub> into progressively larger volumes bridging the volume difference between the SV and LV. Other gases, such as N<sub>2</sub> or argon, can be used to examine uncertainties. To remain consistent with previous records, only temperatures from probes 1 and 2 are used in the volume ratio calculation. Sensitivity tests have been done to validate this procedure.

### 6.3 Manometer Data

Data from a manometer run are stored in a text file, named according to date and sample ID. Currently, the data acquisition program stores readings from the pressure sensor and four temperature sensors located inside the oven. Temperatures are stored either in raw form (resistance) (for probes 1-3) with sensor calibration coefficients or in processed form (deg C) (probe 4 and more recently probes 1-3). The pressure and temperature of the sample ( $P_2$ ,  $T_2$ ) and

Version	Effective Date	Authors	Approval	Filename
2.2.0	June 8, 2026	AMC	IV	TP_primary_manometer_v2.2.0.doc

## Technical Procedure: Determination of CO<sub>2</sub> in Air Using the NOAA Manometer

---

extracted CO<sub>2</sub> ( $P_1$ ,  $T_1$ ) are determined from an average of 4-10 measurement periods, where each measurement period is ~30 seconds. Data files are stored on the data acquisition computer and also on a system that is regularly backed-up. Provisional values of CO<sub>2</sub> mole fraction are calculated by the data acquisition program, but the final CO<sub>2</sub> mole fraction associated with a manometric run is calculated off-line. Calibration coefficients for temperature and pressure, and a history of volume ratios are stored in a look-up table. The off-line data processing program accesses these data according to analysis date (section 6.1)

Results from each valid manometer run are stored in a database. The operator may abort a run prior to extraction if a stable and consistent CO<sub>2</sub> mole fraction cannot be obtained during the filling steps (see 5.3, step 4d). Results from a run that is aborted or otherwise determined to be invalid should be flagged as such.

### 6.4 Uncertainties

The uncertainty of the WMO mole fraction scale is described in Zhao and Tans (2006) and Hall et al. 2021. Sources of uncertainty include: measurements of pressure and temperature, the volume ratio determination, adsorption of CO<sub>2</sub> on surfaces, permeability of CO<sub>2</sub> through O-rings, imprecision in the CO<sub>2</sub> extraction step, and uncertainty in the 2<sup>nd</sup> Virial coefficients. The combined uncertainty in the WMO CO<sub>2</sub> scale estimated from repeated measurements of the primaries and an estimate of uncertainties in  $T$ ,  $P$ , and volume ratio is estimated to be ~0.055% ( $k=2$ ) (Hall et al., 2021).

### 7.0 CO<sub>2</sub> Calibration Scale

The measurement of CO<sub>2</sub> in primary standards ultimately leads to the establishment of a calibration scale. Primary standards are measured using a suitable method, such as NDIR or laser spectroscopy, and a response function is derived. Primary standards are value-assigned based on multiple determinations of the response function. The scale is identified as WMO-CO<sub>2</sub>-YYYY, where YYYY is the year in the scale was adopted. The current scale, WMO-CO<sub>2</sub>-X2019, is based on the manometric calibration history from 1996 through 2020 and harmonization using laser spectroscopy.

### 8.0 Safety

It is GML policy to follow safe working practices when handling compressed gas cylinders and laboratory chemicals. Compressed gas cylinders should be secured whenever possible. Personal protective equipment (PPE) should be used when working with hazardous chemicals or in a high noise environment.

Version	Effective Date	Authors	Approval	Filename
2.2.0	June 8, 2026	AMC	IV	TP_primary_manometer_v2.2.0.doc

## 9.0 Documentation

The measured CO<sub>2</sub> mole fraction of each primary standard is recorded in a database along with the date of measurement and other pertinent information. Calibration certificates obtained from accredited testing laboratories (for temperature and pressure sensors, for example) are stored in a 3-ring binder. GML-issued calibration certificates are not prepared for primary CO<sub>2</sub> standards.

Significant notes relating to the performance and maintenance of the analytical system, including software, should be recorded using ELOG (an electronic record system).

Version	Effective Date	Authors	Approval	Filename
2.2.0	June 8, 2026	AMC	IV	TP_primary_manometer_v2.2.0.doc

## Technical Procedure: Determination of CO<sub>2</sub> in Air Using the NOAA Manometer

---

### 10.0 Appendix

#### 10.1 Abbreviations

A2LA	American Association for Laboratory Accreditation
LV	Large Volume
NDIR	Non-Dispersive Infra-Red (analyzer).
NVLAP	National Voluntary Laboratory Accreditation Program
SV	Small Volume

#### 10.2 Equipment

The following equipment are critical to the functions described in this TP.

Item	Manufacturer	Model Number
Oven	Yamato	DH62
Valves	Glass Expansion	PNK3
Glass manifold/volumes	custom (Allen Scientific Glass)	
Vacuum gauge (3)	Granville Phillips	Convectron/pirani-type
Vacuum gauge (piston gauge)	MKS	120AA-000.1RBJ
Gauge Controller	Granville Phillips	316
Piston Gauge	Ruska (Fluke)	2465A-725
Piston Gauge Autofloat Controller	Ruska (Fluke)	2465A-200
Piston Gauge Mass Set	Ruska (Fluke)	2465A-797
Pressure Gauge	Ruska (Fluke)	7050i
Pressure Gauge	Paroscientific	715
Piston Assembly	Ruska (Fluke)	serial # TL-1238
Spare Piston Assembly	Fluke	serial # TL-1794
Secondary Pressure Standard	Fluke	RPM4
Platinum Resistance Thermometer (2)	Azonix	A12001
Platinum Resistance Thermometer	Hart Scientific	5613
Mass Flow Controller (2)	Edwards	825MF
MFC Controller	Edwards	1605
CO <sub>2</sub> analyzer (NDIR)	Li-Cor	LI-7000
Switch/control unit (2)	HP	3488A
Multimeter	HP	34401A
Multimeter	HP	3478A
Digital Thermometer	Hart Scientific	1529 Chub-E4
Turbo-pump (with spare)	Varian	Mini-Task

Version	Effective Date	Authors	Approval	Filename
2.2.0	June 8, 2026	AMC	IV	TP_primary_manometer_v2.2.0.doc

## Technical Procedure: Determination of CO<sub>2</sub> in Air Using the NOAA Manometer

---

Turbo-pump	Varian	IDP-7
Alcohol bath	Kinetics	MC480A1
Chart recorder	Linseis	L2005
Computer	HP	300 series
Computer	Dell	

Version	Effective Date	Authors	Approval	Filename
2.2.0	June 8, 2026	AMC	IV	TP_primary_manometer_v2.2.0.doc

10.3 Drawings

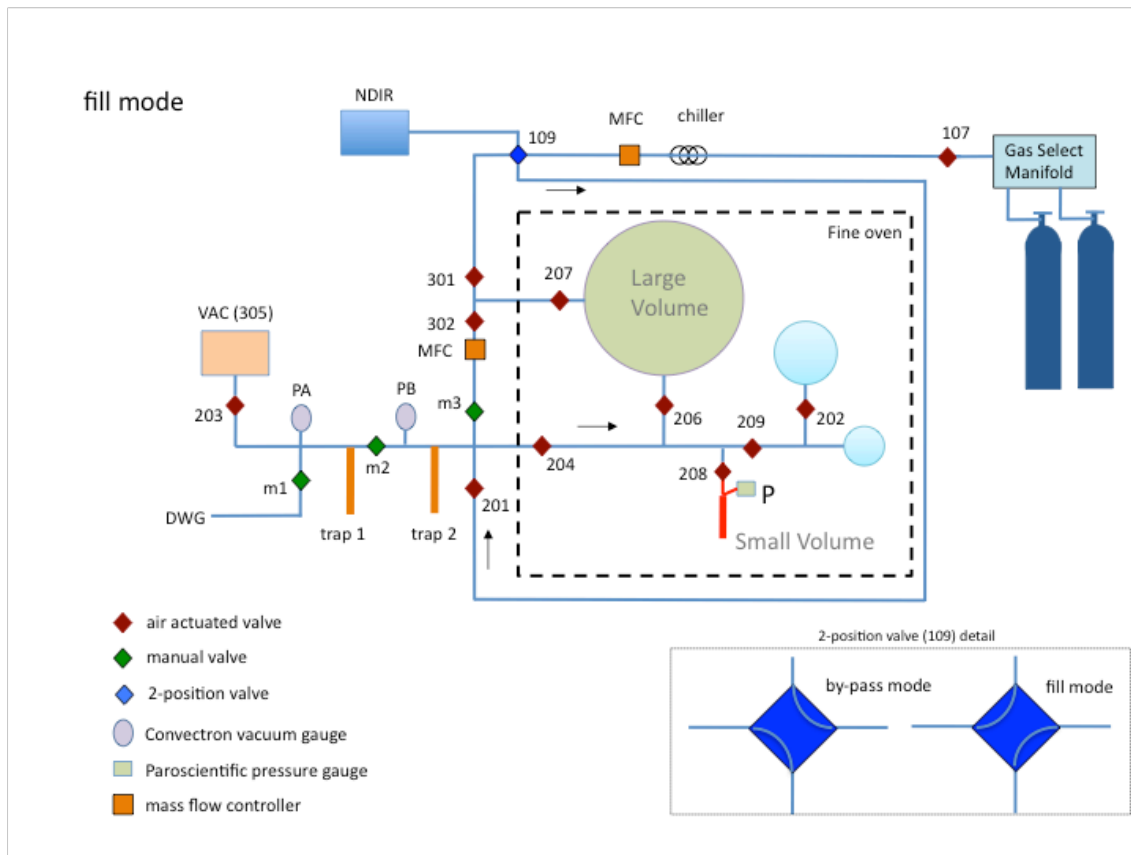

Fig A1. Schematic of NOAA manometer in fill mode.

Version	Effective Date	Authors	Approval	Filename
2.2.0	June 8, 2026	AMC	IV	TP_primary_manometer_v2.2.0.doc

# Technical Procedure: Determination of CO<sub>2</sub> in Air Using the NOAA Manometer

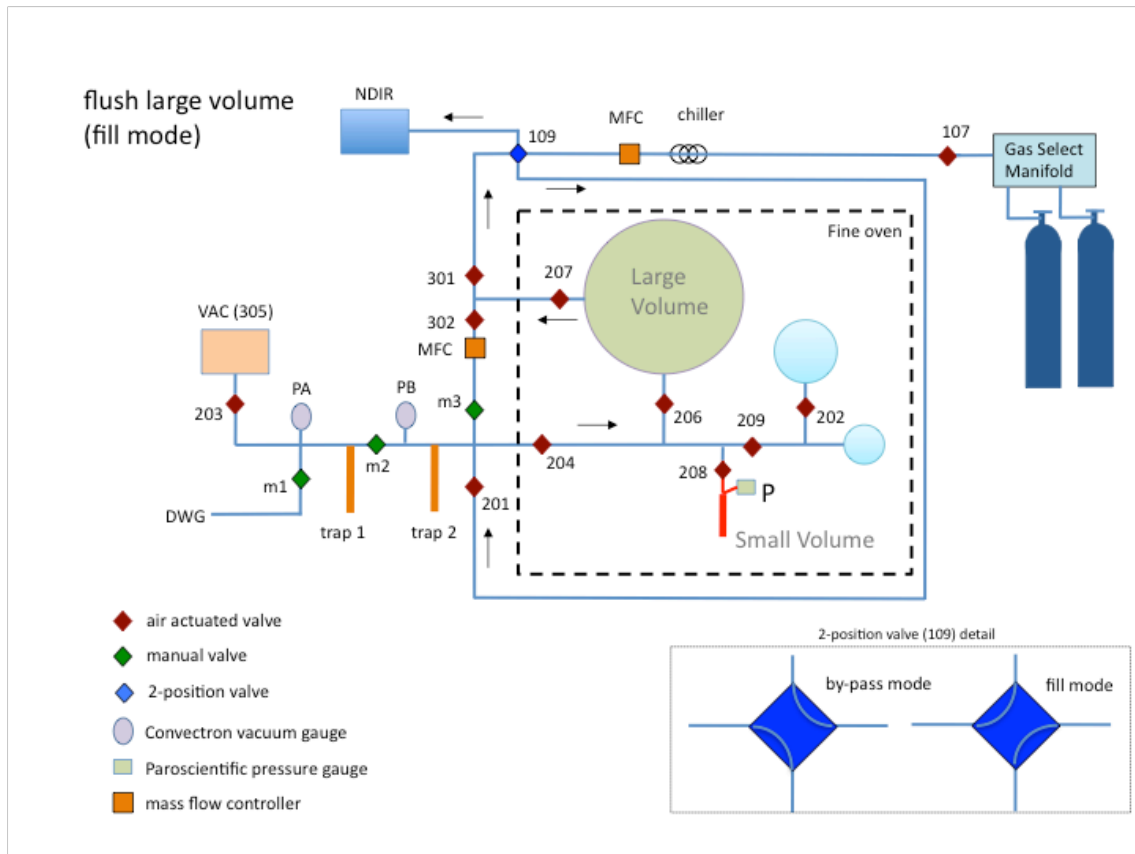

Fig A2. Schematic of NOAA manometer in fill mode, flushing gas through the large volume.

Version	Effective Date	Authors	Approval	Filename
2.2.0	June 8, 2026	AMC	IV	TP_primary_manometer_v2.2.0.doc

# Technical Procedure: Determination of CO<sub>2</sub> in Air Using the NOAA Manometer

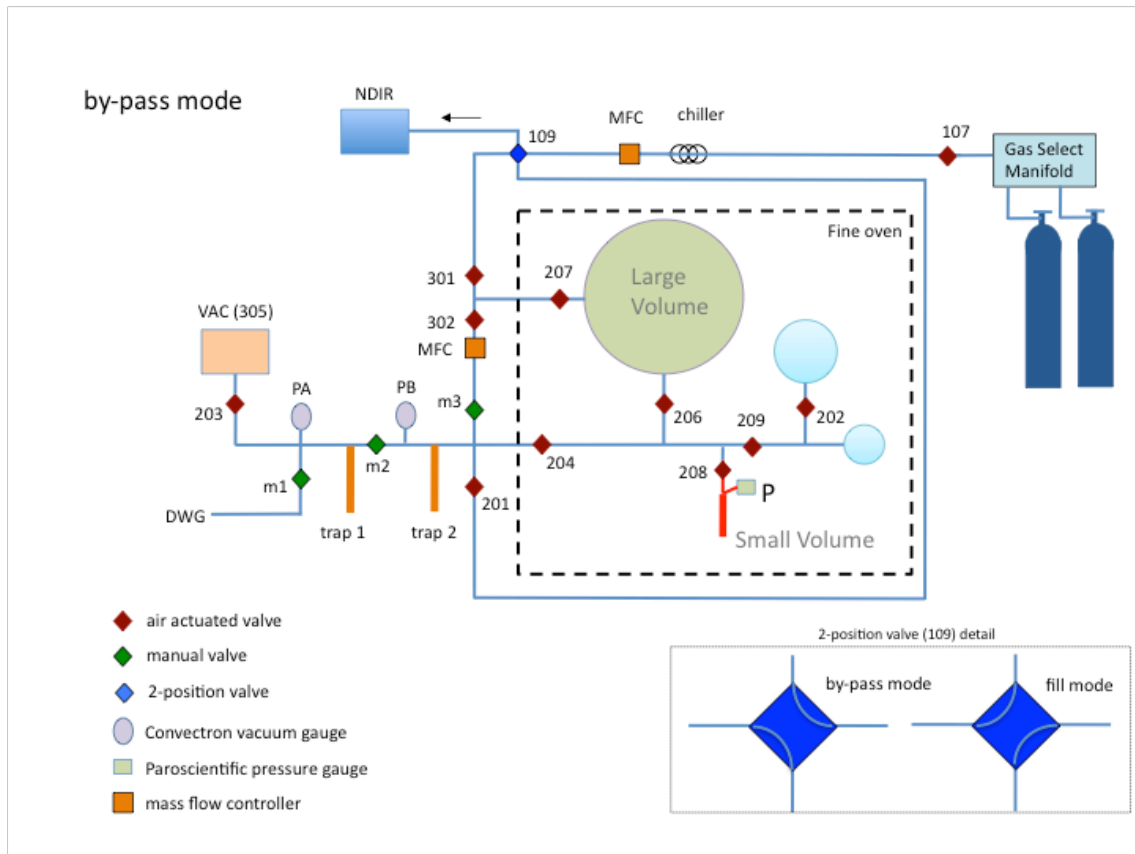

Fig A3. Schematic of NOAA manometer in by-pass mode.

Version	Effective Date	Authors	Approval	Filename
2.2.0	June 8, 2026	AMC	IV	TP_primary_manometer_v2.2.0.doc

## Technical Procedure: Determination of CO<sub>2</sub> in Air Using the NOAA Manometer

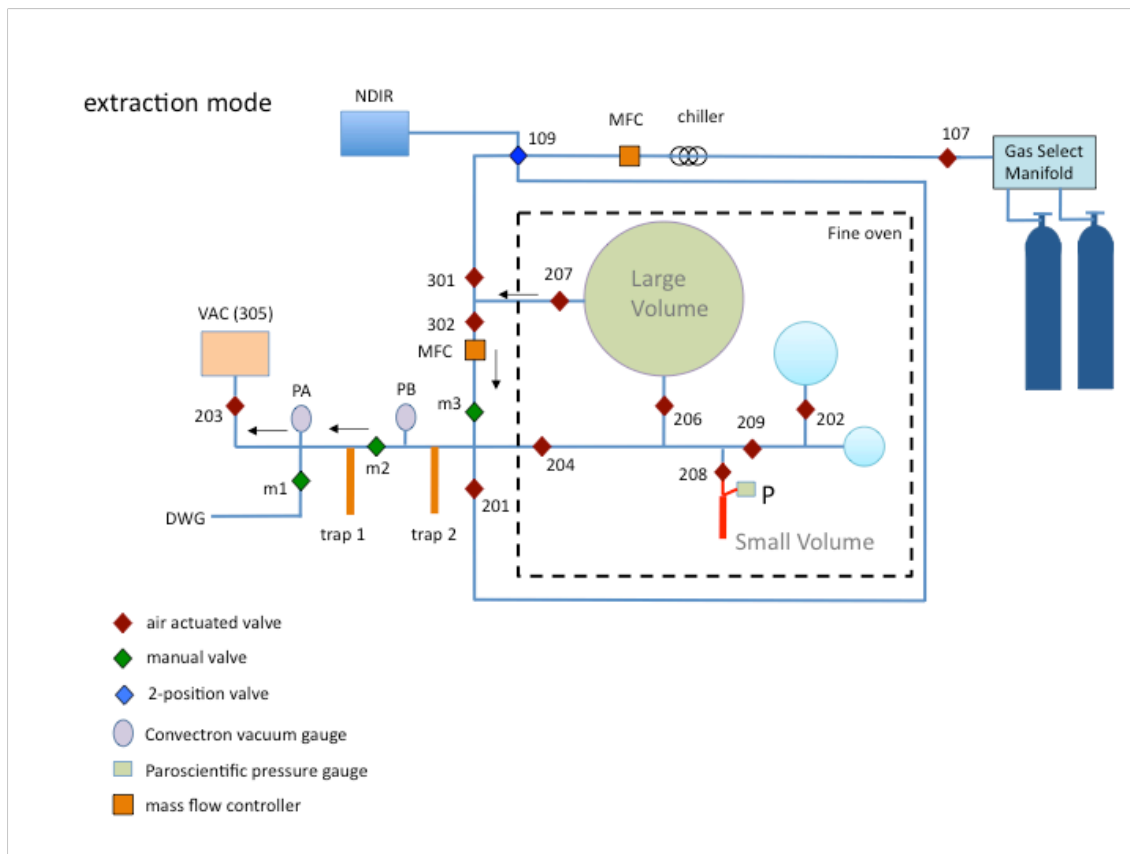

Fig A4. Schematic of NOAA manometer in extraction, or trapping, mode (CO<sub>2</sub>, N<sub>2</sub>O, and water vapor are collected in traps 1 and 2).

### 10.4 Data example

*Raw Data collected during a manometer run*

Header:

10/31/2017

0.0216

Time	Pressure_raw	R1	R2	R3	T4	CO2_prelim	T_paro
1	84.0801	114.5272	114.4845	114.5119	36.53	0	37.18
2	84.0806	114.529	114.4858	114.5138	36.53	0	37.18
3	84.0809	114.5294	114.4863	114.5146	36.53	0	37.18

Version	Effective Date	Authors	Approval	Filename
2.2.0	June 8, 2026	AMC	IV	TP_primary_manometer_v2.2.0.doc

## Technical Procedure: Determination of CO<sub>2</sub> in Air Using the NOAA Manometer

---

4	84.0811	114.5297	114.4871	114.515	36.53	0	37.19
5	84.0813	114.5303	114.4869	114.5154	36.53	0	37.19
6	84.0815	114.5309	114.4878	114.5161	36.53	0	37.18
28	24.9517	114.4054	114.4031	90.4807	36.27	337.6	37.08
56	25.7408	114.4245	114.4236	96.9649	36.27	348.3	37.07
83	26.2826	114.4397	114.4387	100.7021	36.27	355.64	37.07
111	26.6624	114.4544	114.4527	103.4361	36.28	360.78	37.07
139	26.9564	114.4683	114.4642	105.7201	36.28	364.76	37.06
167	27.182	114.4797	114.4741	107.4734	36.29	367.81	37.06
194	27.3529	114.4895	114.4808	108.7852	36.3	370.12	37.06
222	27.4872	114.4981	114.4872	109.7605	36.31	371.93	37.06
250	27.5982	114.5057	114.4913	110.5255	36.31	373.42	37.06
278	27.6905	114.5105	114.4929	111.1224	36.32	374.66	37.06
306	27.7639	114.5136	114.4932	111.5955	36.33	375.65	37.06
334	27.8232	114.5165	114.492	111.9569	36.34	376.44	37.06
362	27.8727	114.5204	114.4947	112.2203	36.35	377.1	37.06
389	27.9132	114.5257	114.4985	112.4227	36.36	377.63	37.06
417	27.9461	114.5287	114.5	112.5781	36.37	378.07	37.06
445	27.9738	114.5309	114.5004	112.7028	36.38	378.43	37.06
472	27.9972	114.5322	114.5001	112.8033	36.39	378.74	37.06
500	28.0171	114.5336	114.5003	112.8984	36.4	379	37.06
528	28.0331	114.537	114.503	113.017	36.41	379.2	37.07
556	28.0472	114.5403	114.5064	113.1763	36.42	379.38	37.07
583	28.0593	114.5429	114.508	113.2925	36.43	379.54	37.07
611	28.0693	114.5422	114.506	113.3726	36.43	379.66	37.07
639	28.0781	114.5383	114.4999	113.4304	36.44	379.77	37.07
666	28.0862	114.5355	114.4951	113.477	36.45	379.88	37.08
694	28.0944	114.536	114.4957	113.5205	36.45	379.98	37.08
721	28.1025	114.5376	114.4978	113.5566	36.46	380.08	37.08

### *Processed Data*

Analysis date: 31 Oct 2017  
 Processing date/time: 20171102 075717

Cycle	time	Pressure	T1	T2	T3	T4	CO <sub>2</sub> _processed
-6	1	84.0548	36.545	36.533	36.537	36.53	0
-5	2	84.0553	36.549	36.536	36.542	36.53	0
-4	3	84.0556	36.55	36.537	36.544	36.53	0

Version	Effective Date	Authors	Approval	Filename
2.2.0	June 8, 2026	AMC	IV	TP_primary_manometer_v2.2.0.doc

## Technical Procedure: Determination of CO<sub>2</sub> in Air Using the NOAA Manometer

---

-3	4	84.0558	36.551	36.539	36.545	36.53	0
-2	5	84.056	36.553	36.539	36.546	36.53	0
-1	6	84.0562	36.554	36.541	36.548	36.53	0
1	28	24.9294	36.236	36.326	-23.858	36.27	337.689
2	56	25.7184	36.284	36.378	-7.676	36.27	348.332
3	83	26.2602	36.323	36.416	1.689	36.27	355.634
4	111	26.64	36.36	36.452	8.557	36.28	360.741
5	139	26.934	36.395	36.481	14.307	36.28	364.689
6	167	27.1595	36.424	36.506	18.728	36.29	367.714
7	194	27.3304	36.449	36.523	22.04	36.3	370.006
8	222	27.4647	36.471	36.539	24.504	36.31	371.803
9	250	27.5757	36.49	36.55	26.438	36.31	373.29
10	278	27.668	36.502	36.554	27.948	36.32	374.531
11	306	27.7414	36.51	36.555	29.146	36.33	375.52
12	334	27.8007	36.518	36.552	30.061	36.34	376.321
13	362	27.8502	36.528	36.558	30.728	36.35	376.982
14	389	27.8907	36.541	36.568	31.241	36.36	377.517
15	417	27.9236	36.549	36.572	31.634	36.37	377.955
16	445	27.9513	36.554	36.573	31.95	36.38	378.327
17	472	27.9747	36.558	36.572	32.205	36.39	378.642
18	500	27.9946	36.561	36.573	32.446	36.4	378.909
19	528	28.0106	36.57	36.58	32.746	36.41	379.117
20	556	28.0247	36.578	36.588	33.15	36.42	379.297
21	583	28.0368	36.585	36.592	33.445	36.43	379.455
22	611	28.0468	36.583	36.587	33.648	36.43	379.594
23	639	28.0556	36.573	36.572	33.794	36.44	379.729
24	666	28.0637	36.566	36.56	33.912	36.45	379.851
25	694	28.0719	36.567	36.561	34.023	36.45	379.96
26	721	28.08	36.571	36.566	34.114	36.46	380.064
27	748	28.0889	36.573	36.568	34.185	36.46	380.183
28	776	28.0963	36.571	36.564	34.244	36.47	380.287
29	803	28.1022	36.569	36.561	34.299	36.47	380.37
30	831	28.1071	36.57	36.563	34.348	36.48	380.435
31	859	28.1115	36.577	36.57	34.406	36.48	380.485
32	886	28.1151	36.582	36.575	34.464	36.49	380.528
33	914	28.1175	36.583	36.576	34.498	36.49	380.559

Version	Effective Date	Authors	Approval	Filename
2.2.0	June 8, 2026	AMC	IV	TP_primary_manometer_v2.2.0.doc

## Technical Procedure: Determination of CO<sub>2</sub> in Air Using the NOAA Manometer

---

34	942	28.1192	36.581	36.574	34.538	36.5	380.584
35	970	28.1205	36.581	36.571	34.572	36.5	380.604
36	997	28.1216	36.581	36.572	34.592	36.5	380.618
37	1025	28.1223	36.582	36.571	34.635	36.51	380.628
38	1053	28.123	36.58	36.569	34.713	36.51	380.64
39	1081	28.1238	36.579	36.568	34.882	36.51	380.652
40	1109	28.1255	36.582	36.571	35.237	36.52	380.672
41	1136	28.1273	36.585	36.575	35.608	36.52	380.691
42	1164	28.1287	36.587	36.576	35.882	36.52	380.708
43	1192	28.1298	36.585	36.574	36.078	36.52	380.726
44	1219	28.1307	36.584	36.572	36.214	36.53	380.74
45	1247	28.1318	36.586	36.575	36.315	36.53	380.751
46	1275	28.1329	36.593	36.582	36.392	36.53	380.758
47	1302	28.1335	36.596	36.586	36.446	36.53	380.762
48	1330	28.1338	36.596	36.585	36.484	36.54	380.766
49	1357	28.134	36.596	36.584	36.509	36.54	380.77
50	1385	28.134	36.595	36.583	36.529	36.54	380.771
51	1412	28.1338	36.593	36.581	36.541	36.54	380.771
52	1440	28.1337	36.593	36.58	36.55	36.54	380.77
53	1467	28.1334	36.592	36.578	36.558	36.55	380.768
54	1495	28.133	36.589	36.574	36.56	36.55	380.767
55	1523	28.1325	36.586	36.571	36.561	36.55	380.763
56	1550	28.1322	36.585	36.569	36.562	36.55	380.762
57	1578	28.1318	36.584	36.568	36.563	36.55	380.758
58	1606	28.1314	36.582	36.566	36.564	36.55	380.754
59	1633	28.131	36.581	36.564	36.564	36.55	380.751
60	1661	28.1306	36.579	36.563	36.564	36.55	380.747
61	1689	28.1303	36.58	36.564	36.565	36.55	380.742
62	1717	28.13	36.58	36.565	36.567	36.55	380.737
63	1744	28.1296	36.58	36.565	36.567	36.55	380.732
64	1772	28.1292	36.577	36.562	36.566	36.55	380.73
65	1800	28.1288	36.577	36.561	36.566	36.55	380.725
66	1827	28.1289	36.581	36.565	36.571	36.56	380.722
67	1855	28.129	36.584	36.571	36.575	36.56	380.717
68	1883	28.1288	36.587	36.574	36.579	36.56	380.711
69	1910	28.1286	36.588	36.575	36.58	36.56	380.708

Version	Effective Date	Authors	Approval	Filename
2.2.0	June 8, 2026	AMC	IV	TP_primary_manometer_v2.2.0.doc

## Technical Procedure: Determination of CO<sub>2</sub> in Air Using the NOAA Manometer

---

70	1938	28.1281	36.587	36.574	36.58	36.56	380.701
71	1966	28.1277	36.585	36.572	36.577	36.56	380.699
72	1994	28.1271	36.583	36.569	36.574	36.56	380.694
73	2021	28.1269	36.584	36.57	36.575	36.56	380.689
74	2048	28.1269	36.587	36.573	36.578	36.56	380.686
75	2076	28.1266	36.589	36.574	36.579	36.56	380.681
76	2103	28.1264	36.589	36.575	36.58	36.56	380.677
77	2131	28.1262	36.589	36.576	36.581	36.56	380.673
78	2159	28.126	36.591	36.577	36.582	36.56	380.669
79	2186	28.1257	36.592	36.579	36.584	36.56	380.664
80	2214	28.1253	36.59	36.576	36.583	36.56	380.661

### Result Summary

```

CO2 calculations
file = /ccg/co2/mano/2017/20171031_1783
Analysis date:      31 Oct 2017
Processing date/time: 20171102 075717
Method: x2017
Paro Coeff: 0.99995 -.0216
Volume Ratio 879.80
Air measurement: 84.0556 0.0005 36.540 0.002
peak co2+n2o 50 1385 380.771 ppm
prelim result 58 1606 380.754 ppm
slope data: -0.000148 -0.000166 -0.000154
avg slope -.0001562 ppm/s
std dev 0.0000093 ppm/s
correction for CO2 loss -0.251 ppm
correction uncertainty 0.024 ppm

```

```

-----
RESULT          CO2+N2O    381.005 ppm
-----

```

20171031\_1783.result (END)

Version	Effective Date	Authors	Approval	Filename
2.2.0	June 8, 2026	AMC	IV	TP_primary_manometer_v2.2.0.doc